



Residential Asphalt Roofing Manual Design and Application Methods

2014 Edition





Copyright

Copyright© 2014, 2006, 1997, 1993, 1988, 1984 by the
Asphalt Roofing Manufacturers Association

All rights reserved. Printed in the United States of America.
No part of this publication may be copied or reproduced
without the express prior written permission of the Asphalt
Roofing Manufacturers Association (ARMA).

For information, contact ARMA headquarters: National
Press Building, 529 14th St NW, Suite 750, Washington,
DC 20045; Phone: (202) 591-2450, Fax: (202) 591-2445

ARMA acknowledges and appreciates the assistance of the
members of the ARMA Steep Slope Committee and spe-
cifically the editorial task force consisting of:

Ed Todd, Atlas Roofing Corporation

Steven Lawrey & Richard Allan Snyder, CertainTeed
Corporation

William Woodring, GAF

Jay Keating, IKO Production

Eileen Dutton, Malarkey Roofing

John Kouba, Malarkey Roofing

Ed Harrington, Owens Corning

Greg Keeler, Owens Corning

Sid Dinwiddie, PABCO Roofing Products

Roof Assembly Ventilation Coalition



Contents

Foreword	v
----------------	---

Chapter 1:

Typical Asphalt Residential Roofing Products and Their Advantages

Shingles	1
Roll Roofing	4
Underlayments	5
Self-Adhering Shingle Underlayment	5
The Advantages of Asphalt Products	6

Chapter 2:

How Asphalt Roofing Products are Manufactured

Asphalt.....	7
Fiberglass Sheets.....	7
The Manufacturing Process	8
Quality Assurance.....	10
Storage.....	10
Research	11
Fire Resistance	11
Wind Resistance	12
Testing Laboratories.....	13

Chapter 3:

Design Considerations

Code Compliance.....	15
Ventilation.....	15
Ventilation and Moisture Control.....	15
Ventilation Effects on Heating and Cooling Costs	15
Ventilation Effects on Ice Dam Formation	15
Ventilation Design Considerations	16
Additional Ventilation Considerations.....	16
Caution: Unvented Attics.....	17
Slope.....	17
Deck Materials.....	18
Direct Application of Asphalt Shingles Over Insulation or Radiant Barrier Decks	19
Deck Preparation.....	19
Drip Edges	20
Roofing Nails.....	22
Nailing	22
Quantity and Placement of Nails.....	23



Nailing Method.....	23
Nailing Method (High Wind Regions)	24
Primers and Cements.....	25
Roofing Fabric Tapes	25
Impact Resistant Materials.....	25
Storage.....	26
Sustainability.....	26
Reflective (Cool) Roofing.....	26

Chapter 4:

Selecting the Right Asphalt Roofing Product

Exposure and Coverage.....	27
Fire Resistance.....	27
Wind Resistance	28
Aesthetics	29
Summary.....	29

Chapter 5:

Estimating How Much Roofing is Required

Estimating Area (Simple Roofs).....	31
Estimating Area (Complex Roofs)	32
Sum It Up.....	38
Roof Slope	38
Additional Material Estimates.....	39

Chapter 6:

Preparing for the Job

Safety.....	41
Tools	42

Chapter 7:

Deck Preparation — New Construction

Underlayment.....	45
Eave Flashing for Ice Dam Protection.....	47
Valley Underlayment and Flashing.....	48
Chalk Line	50

Chapter 8:

Application of Strip Shingles on New Construction

Shingle Application	51
Valleys	55

**Chapter 9:****Application of Laminated Shingles on New Construction**

Shingle Application	61
Applying the Shingles	63
Valleys	63

Chapter 10:**Flashing**

Flashing Against Sidewalls	69
Flashing Against Front Walls	70
Soil Stacks and Vent Pipes	71
Flashing Around Chimneys	72
Rooftop Solar Mounts	77

Chapter 11:**Hips and Ridges**

Hips and Ridges	79
-----------------------	----

Chapter 12:**Application of Shingles on Low and Steep Slopes**

Low Slope Applications	81
Steep Slope Applications	83

Chapter 13:**Application of Shingles for Reroofing**

Roof Deck Assessment	85
Underlayment	88
Ice Dam Protection	88
Starter and Succeeding Courses (Reroofing)	89
Second and Succeeding Courses	91
Flashing	91
Hips and Ridges	92

Chapter 14:**Application of Non-Self-Adhering Single and Double Coverage Roll Roofing**

Single Coverage	93
Application Parallel to the Eaves	94
Application of Double Coverage Roll Roofing	97
Application Parallel to the Eaves	98
Hips and Ridges	99



Chapter 15:

Application of Self-Adhering Roll Roofing

General Application.....	101
Single Layer Application	102
Double Layer Application.....	102
Triple Layer Application	102

Chapter 16:

Inspection of the Completed Job

Inspection.....	103
Color Shading.....	104

Chapter 17:

Roof Care and Maintenance

Roof Care.....	105
Keeping the Roof Clean.....	106

Glossary	107
-----------------------	-----

Metric Conversion Tables	114
---------------------------------------	-----

ARMA Technical Bulletins	116
---------------------------------------	-----

Index	117
--------------------	-----



FOREWORD

From a modest beginning with the marketing of roll roofing in 1893, the asphalt roofing industry has grown steadily through the years to the point where today it is overwhelmingly accepted as the country's leading supplier of roofing products. More than 80 percent of all residential roofing applied in the U.S. is currently produced by the asphalt roofing industry.

The Asphalt Roofing Manufacturers Association (ARMA) is the voice of the asphalt roofing industry. Founded in 1915, the Association has an impressive record of member service through public information programs, research, educational training, code development and many other activities.

This manual has been prepared by ARMA as a part of its commitment to the asphalt roofing industry and is intended to be a reference book of application techniques that have a history of successful roof performance. It does not, however, contain the only possible methods with which one may obtain satisfactory roof performance.

The manual is used for a variety of purposes. Its primary purpose is to provide practical information to those who sell and install asphalt roofing so that the ultimate purchasers of these products may obtain maximum performance for their roofing dollars.

To those engaged in the specification and distribution of asphalt roofing products, it serves as a dependable reference guide to good roofing practice in the selection and application of asphalt roofing products.

To those engaged in the installation of the product, it serves as a text covering time-proven principles in the application of both asphalt shingles and roll roofing.

To those engaged in the teaching of good roofing application techniques, it serves as an effective educational tool.

While this manual represents the industry's views on recommended application procedures, individual asphalt roofing manufacturers may have specific instructions for specific products. Therefore, it is important to review all instructions contained on or inside the product's packaging before beginning application.

The asphalt roofing products described and illustrated on the following pages are all shown with English dimensions. Asphalt strip shingles, for example, are typically 12" wide and 36" long with a 5" exposure. Metric-size shingles, which have slightly larger dimensions, are being used in the United States market as well. In addition, there are a number of new shingles with unusual sizes.

While the general installation procedures for "new and unusual size" shingles may be similar to those for standard-size strip and laminated shingles, whenever new sizes of shingles are encountered, manufacturers' instructions may vary. Check the packaging carefully for specific application instructions or consult the individual manufacturer.



It is also important to note that the Asphalt Roofing Manufacturers Association does not test, certify or approve products used in connection with asphalt roofing systems. The recommendations contained in this manual reflect application techniques and materials that have been used successfully over many years. If you are considering the use of application techniques and/or deck materials which are not covered in this manual, it is advised that you consult the appropriate asphalt roofing manufacturer for proper guidance.

Finally, grateful acknowledgment is made to the members of the Steep Slope Committee of the Asphalt Roofing Manufacturers Association, who are responsible for developing the recommendations contained in this manual and keeping them up-to-date. Their many years of combined roofing experience and knowledge as well as their extensive assistance and contributions during the preparation of this manual have proven to be invaluable.

WARNING: It is dangerous to walk, climb or work on a roof. To help avoid injury or death, exercise extreme care and follow all applicable safety precautions and procedures, including but not limited to manufacturer's instructions, labels and warnings.



DISCLAIMER OF LIABILITY

This document was prepared by the Asphalt Roofing Manufacturers Association and is disseminated for informational purposes only. Nothing contained herein is intended to revoke or change the requirements or specifications of the individual roofing material manufacturers or local, state and federal building officials that have jurisdiction in your area. Any question, or inquiry, as to the requirements or specifications of a manufacturer should be directed to the roofing manufacturer concerned. **THE USER IS RESPONSIBLE FOR ASSURING COMPLIANCE WITH ALL APPLICABLE LAWS AND REGULATIONS.**

Nothing contained herein shall be interpreted as a warranty by ARMA, either express or implied, including but not limited to the implied warranties of merchantability, fitness for a particular purpose or non-infringement. **IN NO EVENT SHALL ARMA BE LIABLE FOR ANY DAMAGES WHATSOEVER,** including special, indirect, consequential or incidental damages or damages for loss of profits, revenue, use or data, whether claimed in contract, tort or otherwise. Where exclusion of implied warranties is not allowed, ARMA's liability shall be limited to the minimum scope and period permitted by law.



NOTES



CHAPTER 1

TYPICAL ASPHALT RESIDENTIAL ROOFING PRODUCTS AND THEIR ADVANTAGES

Asphalt residential roofing products are classified under three broad groups: shingles, roll roofing, and underlayment.

Shingles and roll roofing are outer roof coverings, meaning they are exposed to the weather and are designed to shed water and withstand the elements. Underlayments provide additional protection beneath the exposed roofing materials.

As outer roof coverings, fiberglass-based asphalt shingles and roll roofing contain three basic components that provide the protection/long-term durability associated with asphalt roofing products. These components are:

- **A core material made of a fiberglass, organic or polyester mat.**
Serves as the support matrix for the other components and gives the product the strength to withstand manufacturing, handling, installation and service conditions.
- **A specially-formulated asphalt coating.**
Provides the long-term ability to resist weathering and remain stable under service temperature extremes.
- **A surfacing of weather-resistant mineral granules.**
Shields the asphalt coating against the sun's rays and adds color to the product.

SHINGLES:

Asphalt shingles are the most common roofing material used in the United States today. They are manufactured as laminated shingles (multi-layer), strip, open tooth and other shingles in a variety of weights and colors.



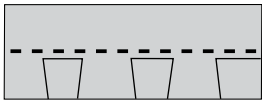
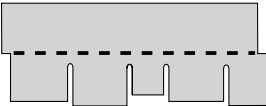
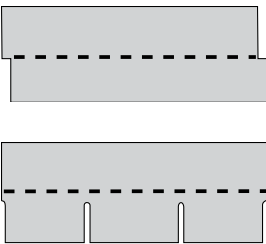
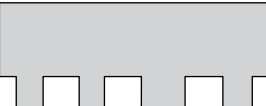

Strip shingles are typically rectangular, and may have multiple cutouts along the long dimension. Cutouts separate the shingle's tabs, which are exposed to the weather and give the roof the appearance of being comprised of a larger number of individual units. Strip shingles are also manufactured without cutouts to produce a much different appearance.

Typical Asphalt Roofing Products and Their Features

Table 1 Typical asphalt shingles

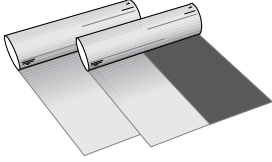
Product	Configuration	Shingles/sq.	Bdls/sq.	Width	Length	Exposure
Laminated self-sealing tab shingle 	Various edge, surface, texture & application treatments.	64-90	3-5	11½"-20" [29.2 cm-51 cm]	36"-40" [91.5 cm-102 cm]	4"-8¼" [10 cm-21 cm]
Multi-tab double exposure self-sealing shingles 	Various edge, multi-tab, and design variations	60-90	4-5	14"-20" [30.5 cm-51 cm]	36"-40" [91.5 cm-102 cm]	4"-6" [10 cm-15 cm]
No-cutout and multi-tab self-sealing square-tab strip shingle 	Various edge and surface texture treatments three-tab or four-tab	48-81	3-4	12"-20" [30.5 cm-51 cm]	36"-40" [91.5 cm-102 cm]	5"-8⅜" [13 cm-21.25 cm]
Open-Tooth, laminated, self-sealing shingles 	Various edge surface, texture & application treatments.	65-90	5-7	12"-20" [30.5 cm-51 cm]	36"-40" [91.5 cm-102 cm]	4"-6" [13 cm-15.25 cm]

Typical Asphalt Roofing Products and Their Features

Table 2 Typical roll roofing products					
Product	Sqs. per package	Width	Length	Intended lap	Exposure
Self-adhering mineral surface roll roofing 	1	36"-39¾" [91.5 cm-101 cm]	32 ² / ₅ '-38' [9.95 m-11.6 m]	2"-4" [5 cm-10 cm]	32"- 37¾" [81 cm-96 cm]
Mineral surface roll double coverage 	0.5	36"-39¾" [91.5 cm-101 cm]	32 ² / ₅ '-38' [9.95 m-11.6 m]	19"-21" [48 cm-53 cm]	17"-19" [43 cm-48 cm]
Smooth surface roll 	1-2	36"-39¾" [91.5 cm-101 cm]	32 ² / ₅ '-72' [9.95 m-22 m]	2"-4" [5 cm-10 cm]	32"-37¾" [81 cm-96 cm]
Non-perforated underlayment 	2-10	36"-54" [91.5 cm-137 cm]	72'-288' [22 m-88 m]	2"-28" [5 cm-71 cm]	17"-50" [43 cm-127 cm]
Self-adhering shingle underlayment 	1-2¼	36"-44" [91.5 cm-112 cm]	36'-75' [11 m-23 m]	2"-6" [5 cm-15 cm]	34"-38" [86.5 cm-96.5 cm]

Most of the shingles are available with strips or spots of a factory-applied, self-sealing adhesive which is a thermoplastic material activated by the heat of the sun after the shingle is on the roof. Exposure to the sun's heat bonds each shingle securely to the one below for wind resistance. During the spring, summer and fall, this self-sealing action usually takes place within a few days of the installation. In winter, the self-sealing action varies depending upon the geographic location, roof slope and orientation of the building on the site.

Weather-resistant mineral granules applied to the top surface of shingles during the manufacturing process not only makes possible the widest range of colors available in roofing materials, but also protect the asphalt from the damaging effects of UV, moisture, and ozone. These granules may contain algae resistant characteristics to control algae growth on the roof.

The tabs of strip shingles may be factory-cut straight or cut offset to obtain straight or staggered leading edges, respectively. They also may be embossed or built up from a number of laminates of base material to give a three-dimensional effect. Each of these shingle characteristics — staggered leading edges, embossing and lamination — can be combined in various ways to create textures on the finished roof surface that resemble tile, wood, or slate.

The typical forms of strip shingles are illustrated, with specifications, in Table 1 on page 2.

This is a list of standards used to demonstrate compliance in North American building codes for shingles:

Shingles:	ASTM D3018, ASTM D3462, CSA A123.5
Fire:	ASTM E108, UL790 & CAN/ULC S107
Wind:	ASTM D3161, ASTM D7158, UL2390 & ASTM D6381
Impact:	ANSI/UL2218
Asphalt Roof Cement:	ASTM D4586, CAN/CGSB 37.5 Cutback Asphalt Plastic Cements
Self Adhering:	ASTM D7505, ASTM D7530, ASTM D1970
Solar Reflectance:	ASTM C1549, ASTM E903, CRRC-1
Thermal Emittance:	ASTM C1371, ASTM E408, CRRC-1

ROLL ROOFING

As the name implies, roll roofing is manufactured, packaged and shipped in rolls. It comes in a wide range of weights and measures (see Table 2 on page 3). Roll roofing products are produced with either a *smooth surface* or a *mineral surface*, the latter of which contains mineral granules that are embedded in the top side of the sheet.

Some mineral-surface roll roofing is manufactured with a granule-free selvage edge that indicates the amount each succeeding course should overlap the preceding course. Others have laying lines on the granule surface to indicate lap location. The manufacturer's recommendations with respect to the side and end laps should be followed.

In addition to its use as a roof covering, roll roofing is also important as a flashing material. Typical roll roofing products are shown in Table 2.

This is a list of standards used to demonstrate compliance in North American building codes for roll roofing:

- ASTM D6380
- CSA A123.2
- ASTM D7505
- ASTM D7530
- ASTM D1970
- ASTM D3909

UNDERLAYMENTS

Underlayments consist of a felt or mat (fiberglass or polyester) that may be impregnated or coated with asphalt, stabilized asphalt coating, polymer-modified asphalt, non-asphaltic polymeric coating or a combination of these materials. They are used as a secondary protection under asphalt shingles, roll roofing and other types of roofing materials. Some of these types of products are also useful as sheathing paper.

Underlayments are manufactured in a variety of sizes and weights.

This is a list of standards used to demonstrate compliance in North American building codes for underlayments:

- ASTM D226
- ASTM D4869
- ASTM D6757
- CSA A123.3
- ICC-ES AC48
- ICC-ES AC188
- ICC-ES AC207
- ASTM D2626

SELF-ADHERING SHINGLE UNDERLAYMENT

Self-adhering shingle underlayments are polymer modified bituminous sheet membranes that can be used in place of, or in addition to, underlayments in critical roof areas. These products resist water penetration caused by the backup of water from ice dams, melting snow or wind. Critical areas where self-adhering shingle underlayments are commonly used include: along the eaves where there is the possibility of ice dams forming, rake edges, valleys, around skylights and chimneys, dormers, slope transition areas and in low slope areas. Self-adhering underlayments are installed by removing the release liner and applying the membrane to the roof deck.

Self-adhering shingle underlayment can also be useful in warmer climates where a similar backup of water can occur from an accumulation of pine needles, leaves and other roof debris.

If a self-adhering shingle underlayment is used, refer to the application instructions under “Eaves Flashing for Ice Dam Protection” on page 47 and consult the manufacturer for specific application instructions.

This is a list of standards used to demonstrate compliance in North American building codes for self-adhering shingle underlayment:

- ASTM D1970
- CSA A123.22
- ICC-ES AC48



THE ADVANTAGES OF ASPHALT PRODUCTS

The dominant leadership of asphalt roofing products through the years has not evolved as a matter of chance. It is based on the long-standing proven product performance that goes beyond the basic roofing requirement of providing a covering that shields the building's inhabitants from the weather.

The product characteristics that have earned asphalt roofing its leading position include the following:

- **Weather resistance**
Asphalt roofing products have demonstrated that they resist sunlight, heat, cold, water and ice.
- **Fire resistance**
Asphalt roofing products are manufactured to comply with ASTM International (ASTM) and/or Underwriters Laboratories (UL) standards for fire resistance (ASTM E 108/UL790 Class A or C). The importance of fire-resistant roofs cannot be overemphasized, because roofs can be vulnerable to fire from external sources such as sparks or brands emitted by nearby fires.
- **Wind resistance**
Asphalt roofing products are manufactured to comply with the wind-resistant standards of UL and/or ASTM (ASTM D3161, UL2390/ASTM D6381, or ASTM D7158).
- **Economy**
Efficient, high-volume production plus relatively low cost of application result in economies that are difficult for competing roofing materials to match. Moderate installation costs combined with long service life gives asphalt roofing products a very low annual or life-cycle cost.
- **Ease of application**
Asphalt roofing is considered to be the easiest of all standard roofing materials to apply.
- **Adaptability**
Because of their flexibility and strength, asphalt roofing products can be applied on a wide variety of roof configurations.
- **Energy savings**
“Cool” asphalt roofing products are available in a variety of colors that reflect a higher percentage of sunlight, may reduce roof surface temperature and may also contribute to reduced energy costs during the cooling season.
- **Aesthetics**
Asphalt roofing is available in many appealing colors, shapes and dimensional depths that provide bold roof appearances. The wide range of asphalt roofing products introduced in recent years offer much greater flexibility in choosing the appearance of a building's exterior than is available with most other types of roofing material.
- **Style suitability**
Asphalt roofing is completely “at home” with most architectural styles, whether contemporary, modern or traditional.
- **Low maintenance**
Properly chosen and applied, asphalt roofing products require little or no regular upkeep and are easily repaired if damaged.



CHAPTER 2

HOW ASPHALT ROOFING PRODUCTS ARE MANUFACTURED

The manufacture of asphalt roofing begins with the processing of raw materials into the principal product components, namely, the asphalt saturants, coatings, mineral surfacings and fiberglass core materials. These components are then combined during the production process to make the finished roofing material. These production line operations combine all materials and cut, trim and package the material. The inline-process is constantly monitored and inspected to ensure the quality of the finished product.

ASPHALT

Asphalt is a unique building material that occurs both naturally and primarily as a carefully refined residue from crude oil refining. Because the chemical composition of crude oil differs from source to source, the physical properties of asphalts derived from various crude oils also differ. However, these properties can be tailored by further processing to fit the application for which the asphalt will be used. Softening point, ductility, flash point and viscosity–temperature relationships are only a few of the properties of asphalt that are important in the fabrication of roofing products.

When it arrives from the refinery, asphalt (referred to as “flux”) is soft and sticky. Coating asphalts are made from flux by an oxidizing process known as “blowing.” During this process, air is bubbled through hot flux. Heat and oxygen cause chemical reactions which change the characteristics of the asphalt. Catalysts may be used in the production of coatings which have slightly different properties. The blowing process is continually monitored and is completed when the desired properties are produced. Asphalt may also be modified with polymers to improve its properties. The asphalt is then pumped to a storage tank prior to delivery to the roofing production line.

Asphalt intended for roofing is processed in specific ways. The asphalt “coating” is used to coat the core material and serve as the medium for adhering mineral surfacing to the roofing. The coating asphalts are reinforced with a mineral stabilizer such as finely ground limestone, slate, fly ash, or trap rock. The stabilizer increases the coating asphalt’s resistance to fire and can improve weathering, flexibility and durability.

FIBERGLASS SHEETS

The period since the late 1950s has seen the introduction of inorganic base materials as an alternate to those made with organic fibers. Instead of cellulose fibers, inorganic cores consist entirely of glass fibers of various lengths and orientations. Since the late 1970s, improved technology has helped establish the fiberglass mat as the predominant substrate in the marketplace.

Fiberglass mat is typically formed by a wet-laid process that produces non-woven mat in a controlled manner to obtain the desired properties of the finished mat.

In the wet-laid process, chopped strands of fiberglass are dispersed in water and formed into a mat.

Excess water is removed using vacuum and a binder is applied to the fiberglass. The binder is cured to provide strength to the finished mat.

Finally, the mat is slit to the desired width while being wound into jumbo rolls for conversion to asphalt roofing products.

The manufacturing process and the mat properties are monitored continuously to assure that the required properties are consistently built into the mat.

THE MANUFACTURING PROCESS

The manufacture of asphalt roofing products is a continuous process performed on a roofing machine that begins at one end with a roll of core material and concludes at the other with the finished product. This sequence of operations builds the product up in stages, adding materials along the way and monitoring their application. Figure 2-1 illustrates the sequence of events. The roofing machine components and principal steps that comprise the manufacturing process include the following:

Dry Looper

To begin the process, a roll of reinforcement substrate is placed on a reel and unwound onto a dry looper or accumulator. The looper acts as a reservoir for core material and allows for continuous operation.

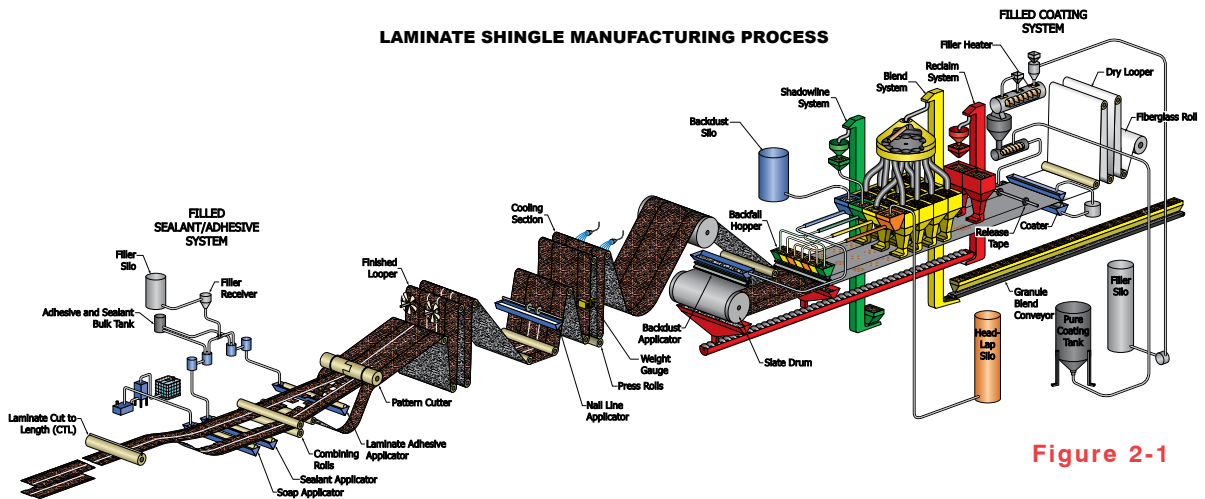

Figure 2-1

Coater

Next, the reinforcing substrate moves to a coater where mineral-stabilized coating asphalt is applied to the top and bottom surfaces simultaneously. The coating asphalt both coats the fibers and fills the voids between them. The clearance between the coating rolls regulates the amount of asphalt applied. Most roofing machines are equipped with automatic scales that keep the product within proper weight specifications.



Mineral Surfacing

After the asphalt coating is applied, both sides of the sheet receive a mineral surfacing. If smooth-surface roll roofing is being manufactured, both sides are covered with a release agent of fine consistency to keep the product from sticking together during shipment and handling. The sheet passes over a series of rollers where the fine particles are adhered to the asphalt and the material is cooled.

If granule surfaced products are being manufactured, the top surface of the sheet is covered with mineral granules of specified color. A series of cooling drums and rollers under controlled pressure embed the granules in the coating asphalt.

Finish or Cooling Looper

Once the mineral surfacing is applied, the sheet is accumulated in the finish looper. Here, the material is cooled prior to being cut and packaged.

Laminator

When manufacturing laminated products, after the sheet is cooled, it goes through a process where it is slit into lanes or ribbons of fabric that are recombined into two or more layers before going into the shingle cutter. The layers of the multi-layered shingle are held together by adhesive.

Application of Self-sealing Adhesives

A self-sealing adhesive is applied by a variety of methods to the front or back of the sheet.

Shingle Cutter

At this point the sheet from the finish looper (or the ribbons from the laminator) goes into the shingle cutter. It cuts the sheet from the back or smooth side. The shingles are mechanically separated and stacked to form a bundle of the appropriate weight and quantity. Bundles are then moved to packaging equipment where they are wrapped, labeled and palletized before being stored in the warehouse or shipped.

Roll Roofing Winder

As roll roofing is being manufactured, the material moves from the finish looper onto a winding mandrel that measures the length of the sheet as it turns. When the proper length of the roll has been wound, the sheet is cut. The roll then has a wrapper applied and is then removed from the mandrel and palletized before warehousing or shipping.

QUALITY ASSURANCE

Prior to introduction into the process, raw materials are subjected to inspection and analysis for conformance to requirements. The process is constantly monitored to assure the product components are combined in the prescribed manner. Throughout the manufacturing process, the roofing material is continually inspected to ensure that the product conforms to specifications. For example, organic felts are monitored to determine the quantity of saturant being absorbed, the efficiency of saturation, as well as thickness, distribution and uniformity of the coating asphalt. Asphalt shingles are monitored for coating uniformity, distribution and thickness. Additionally, tests are made to determine whether the mineral-granule surfacing is distributed uniformly and is properly embedded in the coating. Finally, inspections are made to confirm weight, count, size, coloring and other characteristics of the finished product as it leaves the roofing machine. Most of the products made by manufacturers are certified to meet ASTM material standards, UL Classifications, and specific building code requirements. The certifications are typically printed on the packaging, usually a paper or plastic wrapper.

STORAGE

An important aspect of maintaining the quality of the product that emerges from the manufacturing line is proper storage. Whether at a manufacturing plant, a distributor's warehouse or a job site, certain procedures must be followed to ensure that the finished product will be in prime condition when applied to a roof. In every case, follow the manufacturer's recommendations for storage.

As a general guideline, store shingle bundles in a cool, dry, well-ventilated location in stacks not more than one pallet high. If higher stacking is necessary, use racks or bins that prevent the weight of the bundles on the upper pallets from bearing down on the bundles below.

Systematically rotate all stock so that the material that has been stored the longest will be the first to be moved out (i.e., first in, first out).

Store rolled materials upright on pallets. If several tiers must be stored on top of one another, place plywood sheets between the tiers to prevent damage to the ends of the rolls and to stabilize the stacks.

Arrange stock so that there is ample space for forklifts and other handling equipment to operate without bumping into and damaging materials in the stacks.

It is not recommended to store asphalt roofing products outdoors for extended periods of time. If it must be done, place the materials on a raised platform or pallets so that they are not in contact with the ground. In addition, cover the roofing materials with vented plastic sheets or breathable tarpaulins to protect them from rain or snow. Ventilate the protective covering to allow air to circulate. Avoid storing shingles in the direct sunlight for a long period of time.



RESEARCH

Although asphalt has been used successfully as a building material for many centuries, modern asphalt roofing products are the result of relatively recent research and development efforts by individual manufacturers and the industry as a whole.

Manufacturers maintain their own laboratories and research staffs to provide expertise and service in areas such as raw materials, manufacturing processes and product performance.

Research involving areas of industry-wide interest has been continuously sponsored by ARMA for over 50 years. This research has been conducted by government and private research organizations along with ARMA member companies.

Some of the valuable information these research activities have produced include:

- The effects of mineral stabilizers in coating asphalts.
- The interaction of various fibers on the formation and properties of roofing felts.
- Basic studies of asphalt chemistry to improve the durability of roofing products.
- A rapid method of detecting changes in the crude oil used to produce asphalt.
- Test methods for evaluation of the wind resistance of shingles.
- Granule technology research to develop and improve solar reflectance and algae resistance of mineral surfacing.

The acceptance and established reputation of asphalt roofing prove how well these individual and industry-wide research activities have worked for the ultimate benefit of the end user.

FIRE RESISTANCE

Any number of sources, including chimney sparks, a brush fire or airborne burning brands ejected from a nearby burning building, can ignite a roof covered with a flammable material. Fire resistance, therefore, is an important safety consideration and the reason why many local building codes require that roofing materials conform to certain standards in this respect.

Asphalt roofing manufacturers voluntarily submit their materials to independent testing laboratories that test them in accordance with established standards. The most widely accepted standard for fire resistance in building materials are ASTM E108, “Standard Test Methods for Fire Tests of Roof Coverings,” or UL790, “Tests for Fire Resistance of Roof Covering Materials.”

If the material meets the standard, the product may carry the testing laboratory’s label indicating its class of fire resistance in accordance with the named standard. These classes are listed below.

- Class A — designed to withstand severe exposure to fire
- Class B — designed to withstand moderate exposure to fire
- Class C — designed to withstand light exposure to fire

The material's performance is judged on the basis of three tests that determine its resistance to intermittent flame, flame spread and ignition from burning brands. To earn the appropriate Class A, Class B or Class C rating, the roof covering material must not, at any time during or after each of the tests:

- Blow or fall off the deck as flaming or glowing brands.
- Break, slide, crack or warp to expose the roof deck.
- Allow the roof deck to fall away as glowing particles.
- Allow sustained flaming of the underside of the roof deck.

Most asphalt fiberglass roofing products manufactured in North America carry a Class A rating. The label is evidence that the material will provide the level of fire resistance for which it is rated. Thus, manufacturers usually display the label prominently on their packages to indicate the rating of their product. These standards are backed by regular visits by independent third-party testing labs to manufacturing plants as well as periodic testing of product samples to see that they continue to meet the fire resistance specifications.

WIND RESISTANCE

Most manufacturers certify asphalt shingles to wind performance test standards through independent third-party testing laboratories. Additionally, the building codes now include a requirement for certification of asphalt shingle testing by third-party quality assurance entities. Most shingles are required to comply with ASTM D7158, "Standard Test Method for Wind Resistance of Sealed Asphalt Shingles (Uplift Force/Uplift Resistance Method)." Shingles that do not primarily rely on factory-applied sealants for wind resistance are qualified to meet building codes by testing to ASTM D3161, "Standard Test Method of Wind Resistance for Asphalt Shingles (Fan Induced Method)."

Shingles that have passed the requirements of these test methods are identified with labels on the shingle packaging; the label will include the test method used, and the performance rating that the shingle meets. The building codes include requirements for ratings based on the design wind speed in effect. The codes also require that asphalt shingles be installed in accordance with the manufacturer's installation instructions. These instructions include a variety of directions, including proper alignment and attachment of the shingle to the roof deck, as well as underlayment and flashing details. Recent field studies have shown that installation is a critical component to ensure proper performance.

The performance of asphalt shingles in high wind areas is of great importance to the product manufacturers. In recent years, ARMA has sponsored an extensive wind research program to better understand the performance of asphalt shingles. It was this work that led to the development of ASTM D7158, which is now the primary wind resistance requirement in the building codes for asphalt shingles using factory-applied sealant. ARMA participates in university and building industry research programs so that asphalt shingles will continue to provide appropriate wind performance, and be the product line leading the roofing industry in product performance, test methodology and related research.

Be sure to check with local building codes to verify your local wind resistance requirements.

TESTING LABORATORIES

A detailed listing of third party independent testing laboratories can be obtained from the ASTM International (formerly, American Society for Testing and Materials) or the American Council of Independent Laboratories, Inc.

American Council of Independent Laboratories, Inc.

1875 I St., NW
Suite 500
Washington, DC 20006
Phone: (202) 887-5872

Directory of Testing Laboratories: STP 33 E-ASTM

100 Barr Harbor Drive
West Conshohocken, PA 19428-2959
ATTN: Customer Service Department
Phone: (610) 832-9500



Figure 2-2
Typical mark from independent
testing laboratories



CHAPTER 3 DESIGN CONSIDERATIONS

CODE COMPLIANCE

While this manual covers most steep-slope asphalt roofing requirements and is intended to be consistent with the International Building Code and International Residential Code, check the local building and zoning code for specific code and permitting requirements.

VENTILATION

Proper ventilation of attic areas is an essential factor in realizing the maximum service life from the building materials used in the roof assembly. Proper ventilation removes heat and moisture from the attic space, can help prevent formation of ice dams, and may improve heating and cooling efficiency. Overlooking proper ventilation may result in:

- Premature failure of the roofing including blistering.
- Moisture accumulation in insulation and other roof system components.
- Mold growth and rotting of wood components.
- Roof deck distortion that can cause buckling of the roofing.
- Ice dam formation in cold climates.

VENTILATION AND MOISTURE CONTROL

In colder climates, limiting moisture entry into the roofing assembly can be a challenge especially during winter months. Higher levels of insulation and tighter construction techniques can help seal the roof assembly more effectively against air infiltration, but significant volumes of occupancy-generated water vapor can still be drawn into the attic space. When proper ventilation practices are not followed premature aging and deterioration of structural components and shingles can occur. Use of vapor retarders reduces moisture flow, but does not stop it.

Condensation of liquid water results when water vapor comes in contact with a cold surface such as the underside of a roof deck. That liquid water can soak insulation and adversely affect its thermal resistance performance. It can also cause mold to grow and wood roof decks and structural members to rot. Proper attic ventilation can remove water vapor from the attic space before condensation can occur.

VENTILATION EFFECTS ON HEATING AND COOLING COSTS

During the summer months, radiant heat from the sun can cause high roof deck temperatures, especially in hot climates. Gradually, the entire attic space is heated, and, in turn, the entire dwelling may feel the effect of a hot roof. A properly ventilated flow-through air space beneath the roof deck and above the insulation can significantly reduce heat buildup in the attic.

VENTILATION EFFECTS ON ICE DAM FORMATION

Ice dams are formed when heat from the conditioned space of a building rises into the attic space, warms the underside of the roof deck, melts a portion of the snow layer on the roof causing liquid water to flow down the roof slope to an area of the roof, typically near the eaves, where the roof temperature is below freezing, and refreezes there. Cyclical repetition of this process can lead to formation of an ice dam along the eave behind which a pond of liquid water can form and leak behind shingles. Proper ventilation can reduce the likelihood of the snow melting by keeping the entire roof deck at a more uniformly cold temperature, thus helping to prevent ice dam formation.

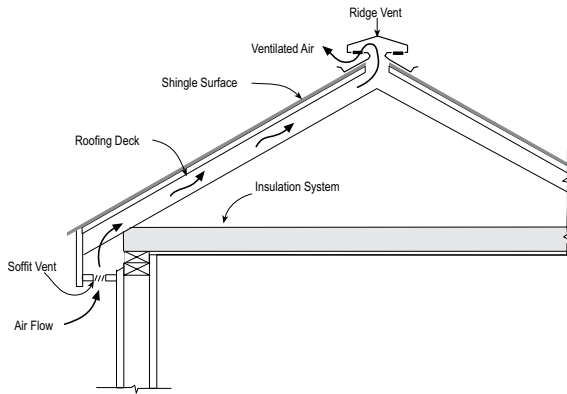

Fig 3-1 Proper Ventilation

With proper ventilation, air will circulate freely under the roof deck and carry away water vapor before it can condense. One of the best methods is a combination of continuous eaves and ridge vents that together provide uniform natural draft ventilation from the bottom to the top of the attic space. Louver and vent openings should not be covered during the winter. Eaves or soffit vents should not be blocked by insulation. Structures with bath and kitchen vents that are vented directly to the attic space should have these rerouted to discharge outside of the structure to remove excess water vapor.

VENTILATION DESIGN CONSIDERATIONS

In addition to complying with any local building code requirements, two key factors should be considered when designing an attic ventilation solution: 1) the total amount of ventilation required and 2) the placement of the intake and exhaust openings to generate optimal free-flow ventilation.

Net Free Ventilation Area (NFVA) describes the area of unrestricted air flow at the intake/exhaust vent openings connecting a ventilated space to the exterior. An intake or exhaust opening exactly one square foot in size that is not covered with anything constitutes one square foot of gross ventilation area. Typically a screen or filter fabric is placed over the opening, thus reducing its gross area to a lower value called the Net Free Ventilation Area (NFVA). Most commercially available roof ventilation products carry a NFVA rating that should be used during the design stage when determining the number of ventilators needed for an attic space.

The code-required minimum amount of ventilation for typical attic spaces, expressed as the Minimum Net Free Ventilation Area ratio, is one square foot of unrestricted air flow for each 150 square feet of attic floor space. This value is established in the building codes and has been demonstrated to provide a sufficient amount of ventilation in most situations. It may be possible to reduce the Minimum Net Free Ventilation Area ratio to as little as one square foot per 300 square feet of attic floor space with design methods including the use of a vapor retarder and/or high and low ventilation locations (explained in the building codes).

Once an appropriate Minimum Net Free Ventilation Area ratio has been selected and the attic floor area has been determined, the square feet of Net Free Ventilation Area required for the attic space can be calculated by multiplying the attic floor area in square feet times the selected Minimum Net Free Ventilation Area ratio.

As important as the cumulative size of ventilation openings is the placement of the openings in the roof assembly. It is considered a best practice to create an approximately balanced combination of intake and exhaust vents to generate optimal free-flow ventilation that system is one in which 50-60 percent of the total required ventilation functions as intake and is located near the eaves or lowest portion of the roof. The remainder of the total required ventilation functions as exhaust and is located on or near the roof ridgeline.

ADDITIONAL VENTILATION CONSIDERATIONS

Exhaust from kitchen and bathroom vent pipes should not be directed into the attic space, but should be vented directly outdoors using a duct that extends through the roof or side walls.

Assure that the attic floor or ceiling insulation does not block the eave/soffit area intake vents.

Ventilating vaulted or cathedral ceiling designs can be challenging. Provide a free ventilation path immediately beneath the roof deck sheathing from an intake vent to an exhaust vent between each rafter pair. See ARMA Technical Bulletin – “Application of Asphalt Shingles to Decks Installed Over Insulation or Radiant Barriers” for additional information. For information about Structural Insulated Panel (SIP) roof assemblies and spray foam insulation applied directly to the underside of the roof deck refer to page 19.

Some jurisdictions require roof vents that resist the intrusion of flames and/or embers to comply with wildfire code requirements. Check with your local code official for specifics.

CAUTION: UNVENTED ATTICS

Recent versions of the model building codes have introduced design guidelines for “unvented attic spaces” that are intended to move the thermal envelope location from the ceiling to the underside of the roof assembly. Energy efficiency may be improved using these designs, especially in areas where HVAC ducts are commonly located in attic spaces. The code provisions for unvented attics include a series of mandatory steps, including detailed instructions on the proper use of vapor retarders and installation of insulation to reduce the likelihood of condensation issues. Although it is possible to create an unvented attic by following the code provisions, it may be a practical challenge for installers. Also, it is very important to ensure that the roof deck assembly design complies with the roofing shingle manufacturer’s installation requirements.

SLOPE

Asphalt shingles are intended to be applied to roof decks having a slope of no less than 2" per foot (2:12). Of all the factors to consider in choosing an asphalt roofing product, one of the most critical is the slope of the roof. It affects the surface drainage of water. These roofs are intended to be water shedding, not a water-proof barrier. Therefore, free drainage dictates the limits within which shingles or roll roofing may be used. Proper consideration of roof drainage can make the difference between a weather-tight roof and one that leaks.

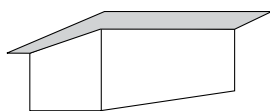

Shed Roof

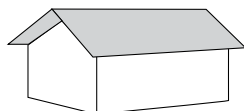

Gable Roof

Figure 3-2
Common roof styles

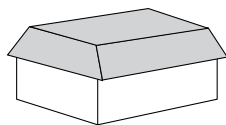

Mansard Roof

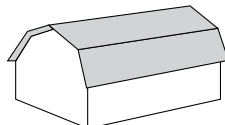

Gambrel Roof

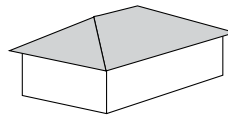

Hip Roof

The slope of a roof is determined in part by its style. A number of common styles are illustrated in Figure 3-2.

In general, most asphalt shingles may be installed on roof slopes from 4" per foot to 21" per foot (4:12 to 21:12) using standard application methods. For roofs having a slope greater than 21" per foot (21:12), special steep slope application procedures must be followed (consult shingle manufacturer's instructions and see page 83). Most asphalt shingles may be used on slopes from 2" per foot (2:12) to less than 4" per foot (4:12) if special low slope application procedures are followed (see page 81).

The minimum slope on which roll roofing may be successfully installed depends on the application method and the type of roll roofing. Roll roofing may generally be used on roof slopes down to 2" per foot (2:12) using the exposed nail method and down to 1" per foot (1:12) using the concealed nail method.

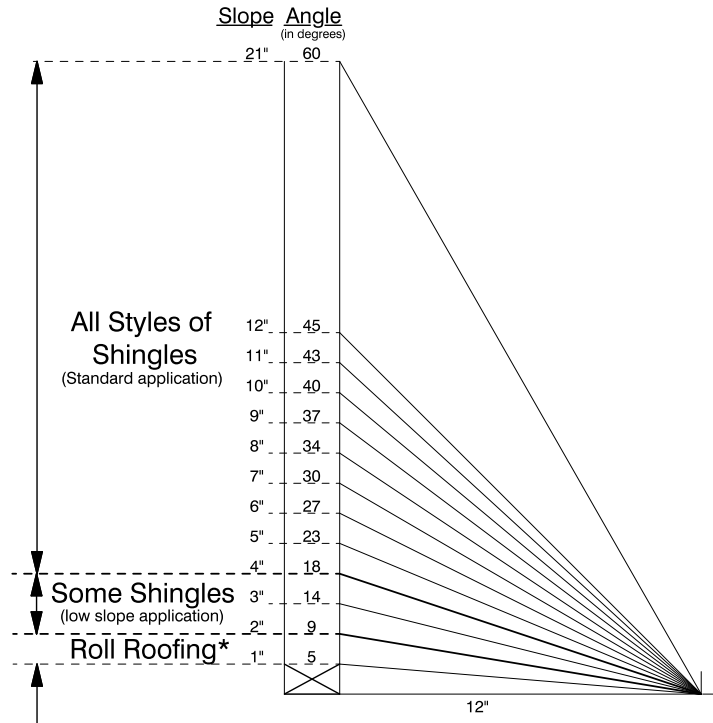

Figure 3-3
 Slope Requirements for
 Asphalt Roofing Products

*Double coverage roll roofing, which typically provides a top lap of 19", may be used on slopes down to 1" per foot. In general, roll roofing should not be used on slopes less than 1" per foot unless specified by the manufacturer.

DECK MATERIALS

[Note]

The type, grade, thickness and installation of structural materials used for roof decks should conform to the requirements of applicable building codes.

The roof deck should be installed in accordance with local building codes with structural sheathing panels rated by building code accredited third-party approval agencies. All wood products must be properly conditioned to be at moisture equilibrium. Failure to use properly conditioned deck materials can result in deck movement, which will distort or damage the overlying roofing materials. Distortion or damage of asphalt roofing materials resulting from deck movement is not a manufacturing defect of the roofing product. To avoid or reduce the appearance of buckles or distortions caused by old lumber roof decks, it is recommended that old and distorted lumber be replaced.

Check with individual roofing manufacturers for their specific requirements for type and thickness of roof decking. Additionally, be sure that the selected roof decking materials comply with local building codes.

DIRECT APPLICATION OF ASPHALT SHINGLES OVER INSULATION OR RADIANT BARRIER DECKS

With today's high cost of energy and the emphasis placed on energy conservation, some homeowners, when reroofing, are applying soft or semi-rigid insulation on the exterior side of the existing roof and then applying asphalt shingles directly over the insulation. Asphalt roofing manufacturers strongly recommend against this practice for the following reasons:

1. Shingles may be damaged or punctured when nailed to a non-rigid surface.
2. The nail-holding power of shingles applied directly over insulation may not be adequate, leaving shingles prone to wind damage.
3. Due to the insulation and radiant barriers preventing heat dissipation underneath the shingles, heat buildup in the assembly may accelerate the weathering and reduce the life of the roof.
4. Fire and wind ratings on asphalt shingles may be affected. Individual systems should be checked with the manufacturer for the appropriate rating.
5. Proper ventilation underneath the roof deck is impossible to accomplish when applying shingles directly over insulation or radiant barriers. See ARMA Technical Bulletin – "Application of Asphalt Shingles over Insulation or Insulated Decks."

Consult the manufacturer for recommendations.

For insulated decks and radiant barriers, it is recommended that a continuous ventilated air space be provided between the top of the insulation and the nailable deck to assist in vapor and heat dissipation.

Structural Insulated Panels (SIP) and below deck spray foam applications are being used for roof decks and they may or may not be approved for use under shingles even if they have an approved nailable surface. Consult the roofing material manufacturer for recommendations for shingle application over SIP products. Some SIP manufacturers are making panels with cavities that provide for through-ventilation.

For more details, see ARMA Technical Bulletin, "Application of Asphalt Shingles to Decks Installed Over Insulation or Radiant Barriers."

DECK PREPARATION

A number of roofing problems may result from failures within the underlying roof structure. Therefore, it is important that the materials supporting the roofing are properly installed.

The underlying structure should provide a rigid deck surface. It should not sag, shift or deflect under the weight of roofing materials, the workers installing the materials or the snow or rain loads the roof may have to support. An unstable structure could lead to movement and may affect the structural integrity and water shedding ability of the roofing and flashing.

Warping as well as other problems may result even with well-seasoned lumber if the attic space under the roof deck or the spaces between the rafters and beams in a cathedral ceiling or mansard roof are not properly ventilated. Roof deck joints should be staggered to minimize the effect of normal deck movement. (See Figure 3-4)

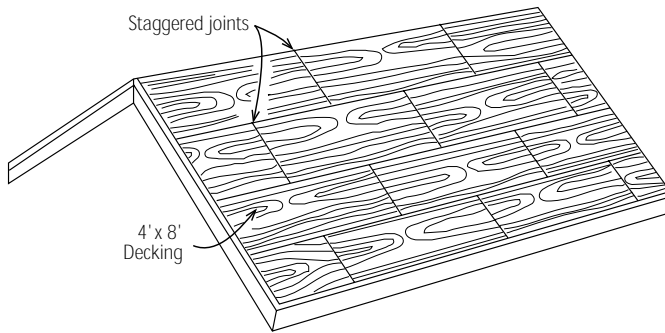

Figure 3-4
 Typical Roof Deck

Inspect the lumber before installation. Do not use any board that is badly warped, has loose knots or has excessively resinous areas. Wood resin may soften and damage asphalt roofing materials.

Always ensure a flat and dry nailing surface before installing deck panels. Follow the deck manufacturer's attachment instructions carefully when installing each panel. For more information, contact APA - The Engineered Wood Association at 7011 S. 19th Street, Tacoma, WA 98466, (253) 565-6600 or www.apawood.org.

If the roof sheathing is already in place, check it for deteriorated or rotted areas, which should be replaced. For excessively resinous areas and loose knots, cover with sheet metal patches. Underlayment must be used before the roofing is applied.

DRIP EDGES

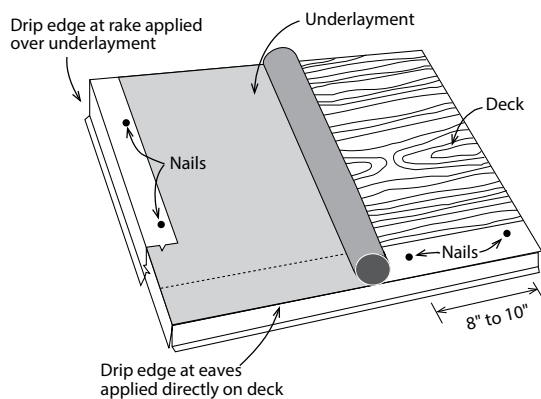

Figure 3-5
 Application of drip edge at rake and eaves

Drip edge provides efficient water shedding at the rakes and eaves and protects the underlying wood from rotting. Drip edge should be made of a corrosion-resistant material that extends a minimum 2" back from the roof edge and bends downward over the fascia.

Apply the drip edge underneath the underlayment along the eaves and over the underlayment on the rakes. Figure 3-5 details the placement and fastening of drip edge in combination with the underlayment. The use of a drip edge is strongly recommended and may be required by local building codes. If no drip edge is used, then all rake and eave overhangs should be $\frac{3}{8}$ " to 1" in width.

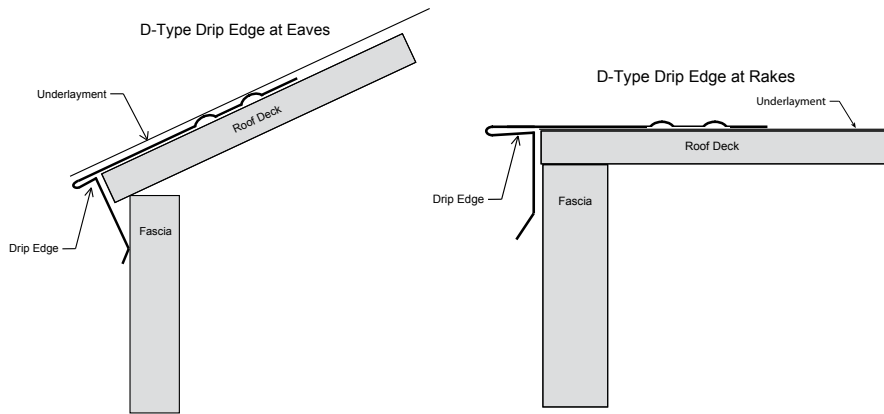

Figure 3-6a
Recommended drip edge

On rake edge:

1. All underlayment goes under the drip edge.
2. Starter course shingle and remaining field shingles can be trimmed flush with drip edge.

On eaves:

1. All underlayment goes on top of drip edge.
2. Starter shingles and field shingles should be aligned flush with the drip edge or with an overhang up to $\frac{3}{4}$ ".

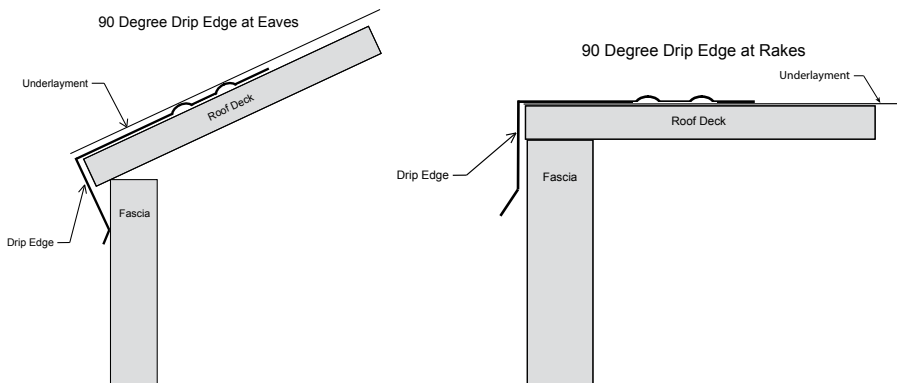

Fig 3-6b
Acceptable drip edge

On rake edge:

1. All regular underlayments go under the drip edge.
2. Self-adhering shingle underlayment may go on top or under the drip edge (See the manufacturer's application instructions).
3. Starter course shingles and remaining field shingles should overhang the drip edge $\frac{1}{4}$ " to $\frac{3}{4}$ ".

On eaves:

1. All underlayment goes on top of drip edge. [See Fig 3-5 and 3-6]
2. Shingles should be aligned to overhang the drip edge $\frac{1}{4}$ " to $\frac{3}{4}$ ".

ROOFING NAILS

It is recommended by ARMA that properly driven and applied roofing nails are utilized as the preferred nailing system for asphalt shingles. Nails are also required in the International Building Code.

Nails

Nails should be made out of galvanized steel, stainless steel, or aluminum and have a nominal shank diameter of 12 gauge, 0.105", and a minimum head diameter of $\frac{3}{8}$ ". Nails will have smooth shanks (except for "gripper marks" sometimes located just below the head) although ring-shanked nails and nails with shank deformations such as "barbs" may be used. For locations within high wind regions, consult the applicable building code and shingle manufacturer for use of ring shank nails.

Corrosion Resistance

Galvanizing by various processes is the typical means of achieving corrosion resistance. Aluminum and stainless steel roofing nails do not require additional coatings for corrosion resistance. Steel nails must be corrosion resistant. Nails should now comply with the requirements of the IRC for corrosion resistance, R905.2.5, which requires compliance with ASTM F1667 and references ASTM A641 Class 1 coating requirements.

Nail Length

Nails should be long enough to penetrate $\frac{3}{4}$ " into the roof deck. Where the deck is less than $\frac{3}{4}$ " thick, the nail should be long enough to penetrate fully and extend at least $\frac{1}{8}$ " through the roof deck.

In determining the nail length, consideration should be given to the number of layers of shingles, shingle thickness(es), underlayment and flashings (eaves, sidewall and valley, etc.).

In some cases, the underside of the deck is exposed to view. In this case, using nails of the recommended length may result in the nail points penetrating through the deck and being exposed to view. Consult the roofing material manufacturer and building code requirements for approved alternatives.

NAILING

Proper nailing is essential to good performance. To ensure proper nailing during shingle application:

- Use the correct type, size and grade of nail as specified in the shingle manufacturer's application instructions.
- Use corrosion resistant nails that comply with ASTM F1667 and A641 Class 1.
- Use the required number of nails per shingle.
- Position the nails as required by the shingle manufacturer.
- Align the shingles properly before nailing to avoid exposing nails in the course below.
- Drive the nails straight and flush with the shingle surface.
- Do not break the shingle surface with the nail head.
- Do not drive nails into knotholes or cracks in the roof deck.
- Repair faulty nailing immediately.

- Follow manufacturer's instructions concerning special nailing procedures for steep slopes, high wind areas, and any special requirements.
- Comply with local building codes

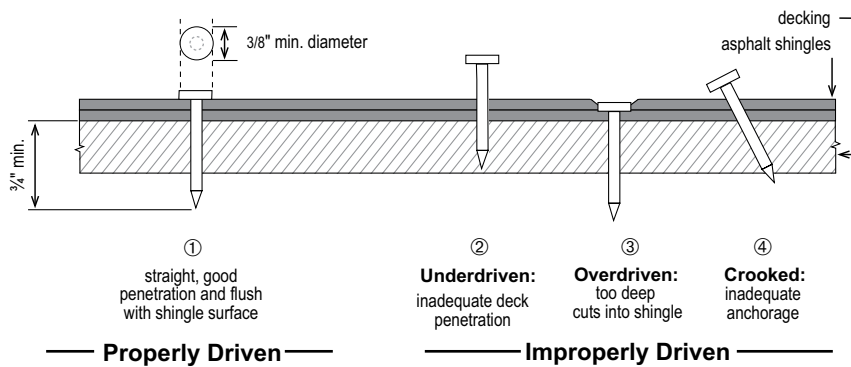

Figure 3-7
Proper and improper
application of
roofing nails

If a nail does not penetrate the deck properly and cannot be tapped down to be properly driven (See Figure 3-7), remove the nail, repair the hole in the shingle with asphalt roofing cement that complies with ASTM D4586 and place another nail nearby. If necessary, replace the entire shingle.

QUANTITY AND PLACEMENT OF NAILS

The following practices reflect the general recommendations of most shingle manufacturers. However, the specific recommendations of the shingle manufacturer, as printed on each shingle wrapper, should be followed when applying shingles.

Align each shingle carefully. Whenever possible, make sure that no cutout or end joint is less than 2" from a nail in an underlying course. Start nailing from the end nearest the shingle just laid and proceed across. This will help prevent buckling. To help prevent distortion, do not attempt to realign a shingle by shifting the free end after two nails are in place. Drive nails straight so that the edge of the nail head does not cut into the shingle. Nail heads should be driven flush with the shingle surface, not sunk into it. Figure 3-7 illustrates examples of proper and improper nailing.

NAILING METHOD

In areas not considered to be high wind regions, the following application methods should be utilized:

A. Placement of nails on three-tab strip shingles

Each of these shingles, both the conventional 36" long shingles and the "metric" shingles, should be fastened with four nails positioned above the exposure. Nail location should be one-inch from each end and centered above each cutout. For details, consult the manufacturer's instructions. (See Figure 3-8)

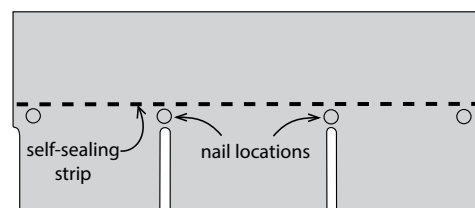

Figure 3-8
Nail locations for
three-tab strip shingle

B. Placement of nails on laminated shingles

Both the conventional 36" long shingles and the "metric" shingles should be fastened with four nails positioned above the exposure. For laminated shingles, locate the nail 1" from each end with two nails equally spaced in between. For details, consult the manufacturer's instructions. (See Figure 3-9)

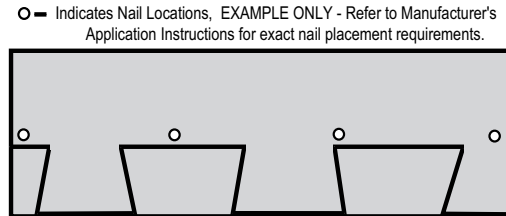

Figure 3-9
Nail locations for laminated shingle

NAILING METHOD (HIGH WIND REGIONS)

(6-nail method)

For areas considered to be high wind regions from historical experience or by local building code authorities, the following six nail method should be considered:

A Placement of nails on three-tab strip shingles

Both conventional 36" long shingles and "metric" shingles should be fastened in accordance with the manufacturer's printed instructions. When six nails are required by the manufacturer or the building code, the nail locations should be on a line $\frac{5}{8}$ " above the top of the cutouts, 1" in from each end, and 1" to the left and right of center of each cutout, or per manufacturer's instruction. (See Figure 3-10)

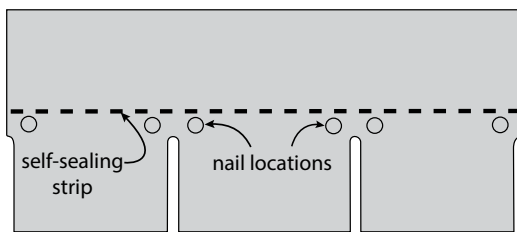

Figure 3-10
Nail locations for three-tab strip shingle

B Placement of nails on laminated shingles

High wind application should comply with the manufacturer's application instructions. Number and location of nails on laminated shingles depend on the product, on the product design, on course offsets, and on approved test application methods. (See Figure 3-11)

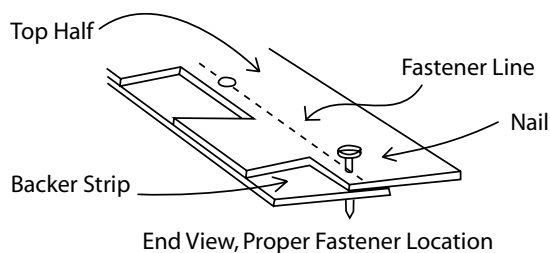

Figure 3-11
Nail locations on laminated shingle

PRIMERS AND CEMENTS

These asphalt-based materials are generally used as sealants and adhesives in roofing work. Most of the primers and cements are combustible. They should never be heated over an open fire or placed in direct contact with a hot surface. If they must be softened before application, place the unopened containers in hot water or store them in a warm place until ready for use. Asphalt-based sealants and adhesives used in roofing work should comply with all current local, state and federal statutes.

In general, apply asphalt primers and cements to clean, dry surfaces. Trowel or brush them vigorously onto the surface to eliminate air bubbles. Check with your roofing manufacturer for approved sealants and adhesives. Primers and cements include the following types:

Asphalt Roofing Cement (ASTM D4586; CAN/CGSB 37.5)

Also known as flashing cement, this material is generally applied to flashings where the roof meets a wall, chimney, vent pipe or other vertical surface. It is formulated to resist flow at the high service temperatures normally encountered in summer. The cement remains pliable at low service temperatures.

Lap Cement (ASTM D3019; CAN/CGSB 37.4)

Generally not as viscous as asphalt roofing cement, lap cement is used to provide a watertight bond between lapping plies of roll roofing. Exposed nails used in conjunction with lap cement should pass through the cement so that the shank of the nail is sealed where it penetrates the deck.

Asphalt Primer (ASTM D41/D41M)

This is an asphalt-based primer used to prepare masonry and metal surfaces for bonding with other asphalt products such as built-up roofing components, asphalt roofing cements or roof coatings. On application, the primer must penetrate the masonry surface pores. Masonry primers have a very fluid consistency and are applied by brushing, rolling or spraying onto the surface.

ROOFING FABRIC TAPES

Made from asphalt-saturated cotton, glass fiber or other porous fabric, roofing tapes are used in conjunction with asphalt cements and coatings with flashings and for patching seams, breaks and holes in metal and asphalt roofs. The tapes are usually available in rolls up to 50 yards long and 4" to 36" wide.

IMPACT RESISTANT MATERIALS

There are asphalt shingle roof covering products available that have been shown to resist damage from impacts. The roofing industry has accepted testing protocols that provide a rating method for various levels of impact resistance of all roof covering materials, including asphalt based shingles. The UL 2218 Test Standard is the most common test method that provides a method to rate the inherent impact resistance of roof coverings from Class 1 (The lowest level of impact resistance) to Class 4 (the highest level of impact resistance). The Classification levels of Class 1, Class 2, Class 3 and Class 4 indicate the levels of measured resistance of a specific roof covering product to various forces of impact. This impact resistance classification is another viable option to consider when choosing roof coverings for new construction or re-roofing, especially for installation in severe weather areas.

STORAGE

Asphalt roofing materials must be kept dry prior to installation. As a result, make provisions at the job site for protecting them against the weather. Because of the importance of proper storage, techniques discussed in Chapter 2 are reemphasized here:

- Never stack shingle bundles more than 4' high.
- Never store asphalt roofing products in direct contact with the ground. Place them on a raised flat platform.
- Never leave the materials exposed to the weather. Cover them with tarpaulins or plastic bags that are vented to provide free air circulation.
- Never store shingles in extreme cold. Store in a warm place prior to application
- Always comply with the manufacturer's published installation instructions when working with asphalt products that have been stored in temperature below 40° F, to avoid potential problems with the product.

SUSTAINABILITY

When it becomes necessary to tear off existing shingles in order to reroof a house, asphalt shingles can be recycled. After the existing shingles have been removed from the roof deck, the roofer may transfer them to a construction waste recycler, rather than to a landfill. The recycler removes any foreign materials, grinds the shingles into small pieces and sends the resulting material to an asphalt plant where it is made into hot-mix asphalt for asphalt paving. This process reduces the amount of construction materials being landfilled while reducing the need for new raw materials.

REFLECTIVE (COOL) ROOFING

Asphalt shingles offer exceptional weather protection as well as deliver pleasing aesthetics. Recent “green” initiatives, energy codes and voluntary standards have prescribed “cool” roofing requirements aimed at conserving energy and reducing smog and greenhouse gases. Advances in roofing granule technology have resulted in the ability to produce a wide range of granule colors that exhibit high solar reflectivity, which may help to reduce air conditioning usage in warmer climates, especially when there is minimal insulation. Dark colored shingles have been developed using these “cool” reflective granules that have equal to or higher solar reflectance values than standard white shingles. Whether white or colored, these special shingles can reflect solar radiation back into the atmosphere thus helping to lower the temperature of the roof surface. Be sure to contact the roofing manufacturer if you have questions, as these shingles are usually recommended in zones that are predominantly cooling rather than heating zones.



CHAPTER 4

SELECTING THE RIGHT ASPHALT ROOFING PRODUCT

There is an asphalt roofing product to meet every roofing requirement, and the “right” product should be chosen based on a number of considerations including local wind conditions, fire ratings, aesthetics and sustainability. On many jobs, several alternatives may exist.

EXPOSURE AND COVERAGE

Exposure is defined as the portion of roofing material that is exposed to the weather after the roofing is installed. The manufacturer specifies the exposure for their various asphalt roofing products. The shingle exposure between courses should not vary more than $\pm 1/4$ " , as this deviation may negatively effect roof performance, especially wind resistance and/or appearance. Shingle sides should be gently butted together to maintain adequate shingle coverage. Typical exposures are given in Tables 1 and 2 in Chapter 1.

Coverage is an indication of the number of layers of weather protection the asphalt roofing provides. Depending on the number of plies or layers of material that lie between the exposed surface of the roof covering and the deck, the material is designated single, double or triple coverage. Where the number of plies varies, coverage is usually considered to be that which exists over most of the roof area. For example, where no significant roof area has less than two thicknesses of material, the installation would be considered double coverage.

Asphalt roll roofing products are typically either single-coverage or double-coverage. Single-coverage rolls provide a single layer of material over most of the roof area. Double-coverage roll roofing is typically applied with a 19" overlap over its 36" width, resulting in a 17" exposure and a minimum of two layers of material. Asphalt shingles are typically considered double-coverage materials because their top lap is 2" or greater than their exposure.

FIRE RESISTANCE

Flying, burning embers from a nearby fire could reach your roof, ignite the roofing material and spread, causing extensive damage to your entire house. For this reason, it is important to know the fire resistance features of the roofing materials you choose.

Today, asphalt shingles carry an independent laboratory’s label indicating that the roofing material used has passed certain tests for fire resistance (see pages 11-12).

WIND RESISTANCE

Windstorms are a major concern to users and manufacturers of various types of shingles. Wind resistance of asphalt shingles can be tested and rated by several methods. Third party certification and markings on the packaging show the material's wind resistance rating. Local history and building code policies will help guide the selection of suitable products for your application.

Most wind resistant shingles depend upon the bonding action of a factory-applied self-sealing adhesive for the majority of their wind resistant strength. Regardless of the type of shingle used for wind protection, it should comply with current code requirements for wind resistance.

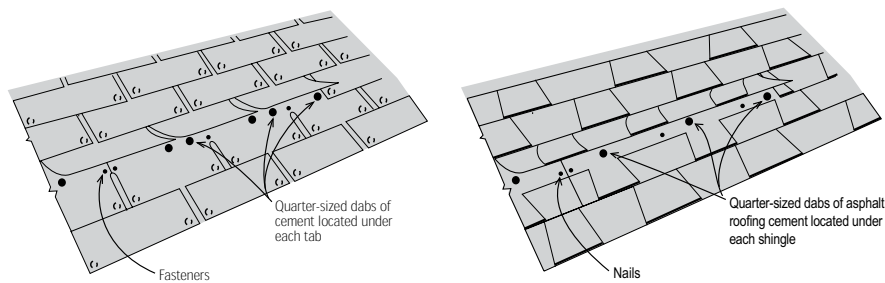

Figure 4-1
Application of
cement under
shingles

The factory-applied adhesive on self-sealing shingles is activated by heat from the sun. In winter when it is cold, bonding can take longer than during warmer seasons of the year depending upon the geographic location, weather, roof slope and direction that the structure faces.

If hand sealing is indicated for any reason, asphalt roofing cement may be used (conforming to ASTM D4586).

Two spots of this cement about the size of a quarter are placed under each tab on three tab shingles. One spot may be placed one to two inches from each end of tab and near the bottom, but not so close to the bottom that it is squeezed out from under the tab as the tab is pressed into the cement. Use four spots of asphalt roofing cement on laminated shingles. Consult the individual shingle manufacturer's recommendations for specific hand sealing instructions. (See Figure 4-1)

During the colder months following installation, it is not uncommon for asphalt shingles to have a tendency to curl at the edges. This phenomenon, known as "cold curl," is due to contraction of the asphalt coating that causes the edges of the shingles to lift. Cold curl is a normal occurrence and should correct itself when the roof warms up either by sunlight or by an increase in the ambient temperature.

Refer to Chapter 3 for proper application in high wind areas.



AESTHETICS

Shingle manufacturers continue to develop shingle aesthetic options. They offer a range of colors and shapes to match anyone's imagination in designing the exterior of a home. Asphalt shingles may also be employed to complement and reinforce the natural colors of other building elements such as brick or stone walls and wood siding.

Roof color can also be utilized in the design of a home to obtain certain psychological effects. For example, a small house may be given added dimension by a light-colored roof that will direct the eye upward and help create a sense of airiness. Dark colors on a tall building or on a building with a steeply-sloped roof will help create the opposite effect, bringing the structure down in scale visually.

In addition to color, the use of asphalt shingles can also contribute to the overall architectural effect of a building. Many of these shingles offer the "look" of wood but with long-term weather resistance and fire safety. Others offer the "look" of slate or tile. All create interesting visual effects of light and shadow over the roof expanse because of their enhanced appearance.

SUMMARY

When selecting asphalt roofing materials, all of the factors discussed in the preceding chapters (slope, coverage, fire, wind resistance, aesthetics and sustainability) should be considered. Inherent characteristics common to all asphalt roofing products, such as ease of installation and repair, should be taken into account when materials other than asphalt roofing are also being considered.



CHAPTER 5 ESTIMATING HOW MUCH ROOFING IS REQUIRED

Various types of asphalt roofing materials and ventilation accessories are required to complete a typical roofing job including shingles or roll roofing, underlayment, starter strips, drip edges, valley flashings and hip and ridge shingles. Before the job begins, estimates of the required quantities of each material, based on calculations derived from the dimensions of the roof, must be made.

Fairly simple calculations are all that are required. Certain measurement and calculation methods also may be used that simplify the process even further. These are described in the following sections along with suggestions on how to take measurements.

[Note]

The most accurate method to measure a roof is from up on the roof. Taking these measurements should be done by a roofing professional. It is not recommended that homeowners climb up on a roof to take these measurements. If a homeowner wants to estimate the size of their roof from the ground there are various resources available on the Internet that can provide assistance.

ESTIMATING AREA (SIMPLE ROOFS)

Roofs come in a variety of shapes and styles but virtually every kind of roof is comprised of plane surfaces that can be subdivided into simple geometric shapes — squares, rectangles, trapezoids and triangles. Thus, roofing area calculations simplify to area calculations for these basic shapes.

The simplest type of roof is one without any projecting dormers or intersecting wings. Each of the illustrated roofs is comprised of one or more rectangles. (See Figure 5-1) The area of the entire roof in each case is the sum of the areas of each rectangle.

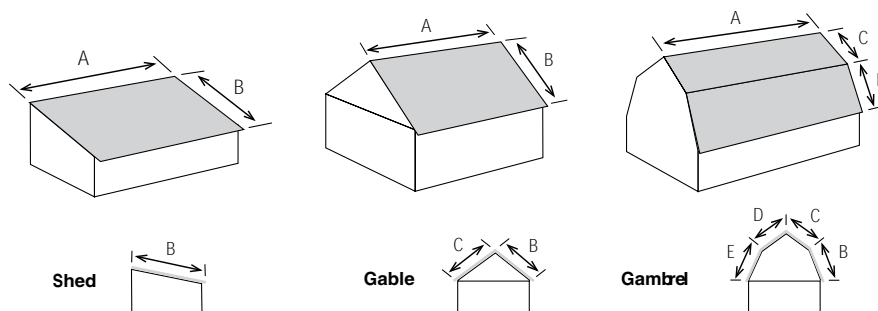

Figure 5-1
Examples of
simple roofs

For the shed roof which has only one rectangle, the area is found by simply multiplying the rake line by the eaves line, or $B \times A$. The gable roof is comprised of two rectangular planes and its area is found by multiplying the sum of the rake lines by the eave line, or $A(B + C)$. For the gambrel roof, four rake lines are involved and the total area calculation is found by multiplying the sum of the rake lines by the eave line, or $A(B + C + D + E)$.

ESTIMATING AREA (COMPLEX ROOFS)

The more complex roofs include those with intersecting wings or dormer projections through the various roof planes. Area calculations for these roofs use the same basic approach taken for simple roofs but involve a number of subdivisions of the roof surface that are calculated separately, then added together to obtain the total roof area.

If plans of the building are available, use them to obtain the required roof dimensions from which area calculations can be made. Otherwise, direct measurements may have to be taken on the roof.

There are many ways in which to calculate the area of a roof. This section will demonstrate one method of how to do it properly. The final answer will be in “squares,” the unit of area measurement used in roofing.

1 square = 100 square feet

Some simple geometry is required to use this method.

The base length (b) times the height (h) of any triangle is twice its area (A). So if you divide the product of the base and height by two, then you have the area of a triangle.

$$(b \times h)/2 = \text{Area of a triangle}$$

Although the following two triangles, r and h , look different from each other, they in fact have exactly the same area.

$$(20' \times 20')/2 = 200 \text{ square feet}$$

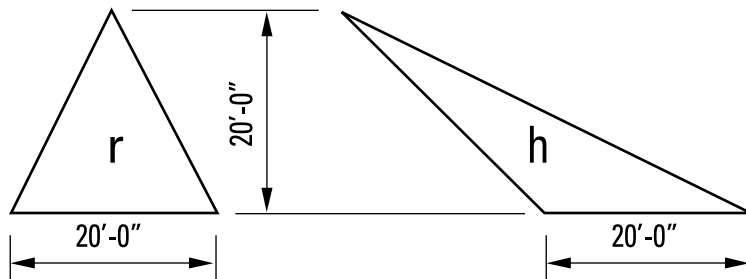

The picture below represents an aerial view of a roof with one hip end and three gable ends. It is strongly recommended that you make a rough sketch of your roof. In order to make it easier for measuring, the roof sketch has been broken up into sections A through F. These sections show the plan view (top looking down) shown in a flat layout even though the roof is not flat.

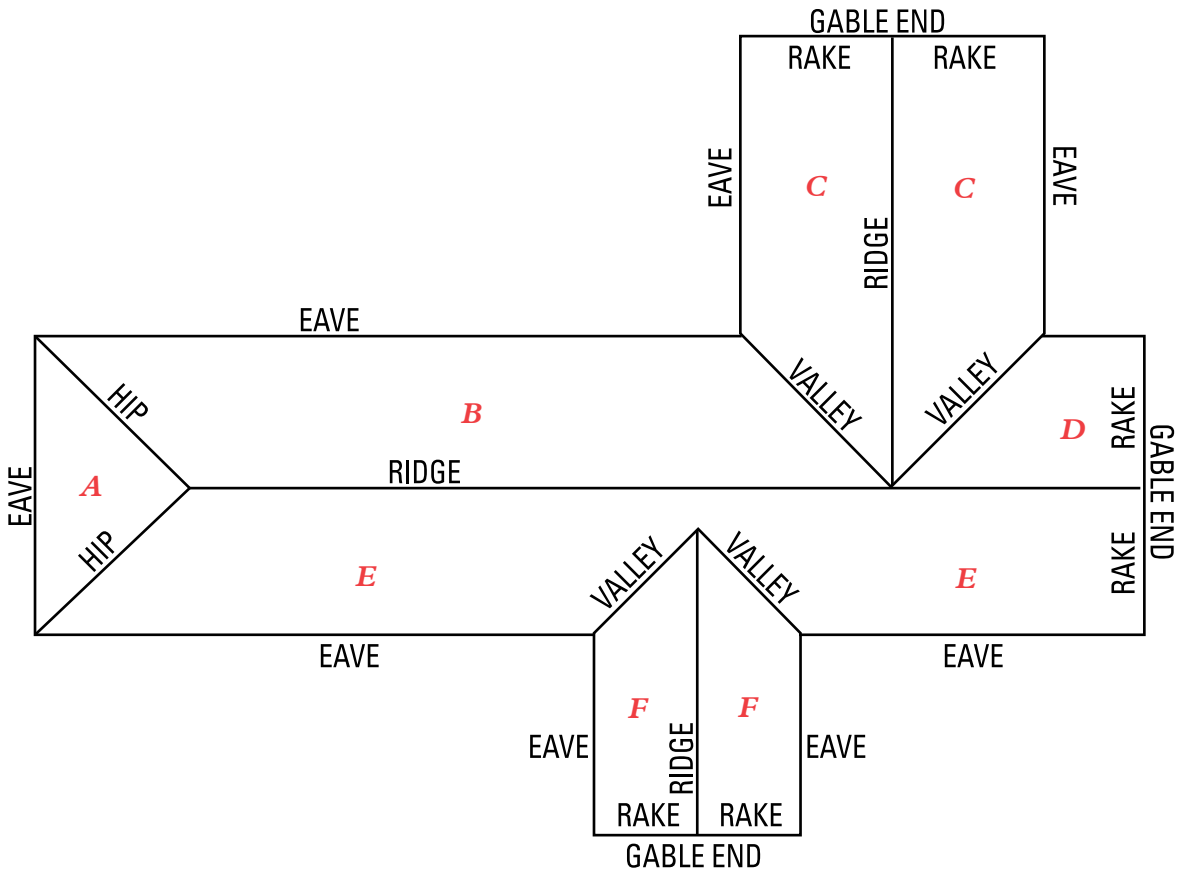

Section A

Section A is a simple triangle. Measure the length of the eave and the perpendicular line from the eave to the peak. Multiply these numbers and divide the answer by two.

$$(30' \times 15')/2 = 225 \text{ square feet}$$

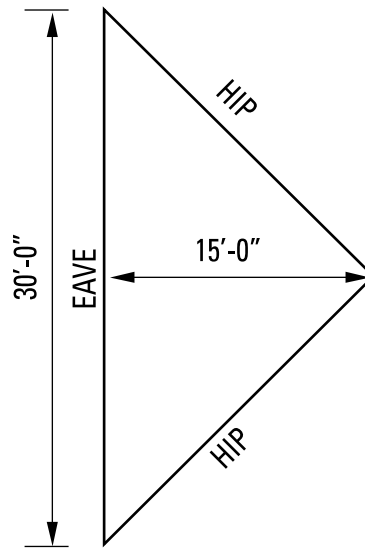

So **Section A** has 225 square feet in it.

Section B

Measure this section by dividing it up into three different sections: x , y , and z . Sections x and z appear to be the same size. However it is a good idea to measure both triangles.

$$x = (15' \times 15')/2 = 112.5 \text{ square feet}$$

$$y = 55' \times 15' = 825 \text{ square feet}$$

Add another 112.5 square feet to our current list of numbers, since z has been determined to be equal to x after measuring.

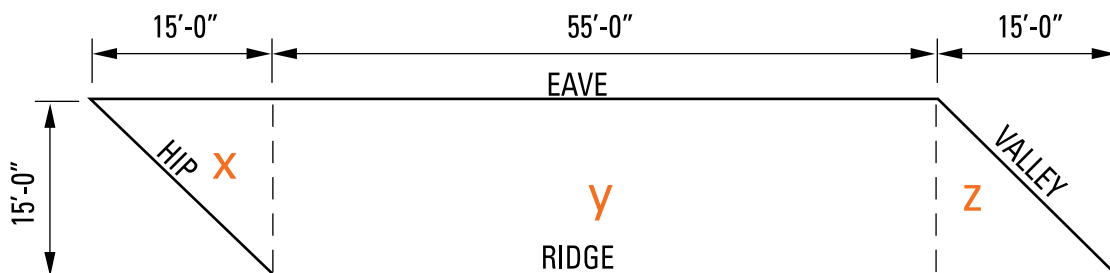

So **Section B** has a total of $112.5 + 112.5 + 825 = 1,050$ square feet.

Section C

As with **section B**, section **C** appears to have symmetrical sides. Divide it up into sections. A quick measurement verifies that x and z are the same as w and y , therefore multiply the sum of w and y by 2 for the final area.

$$w = 30' \times 15' = 450 \text{ square feet}$$

$$y = (15' \times 15')/2 = 112.5 \text{ square feet}$$

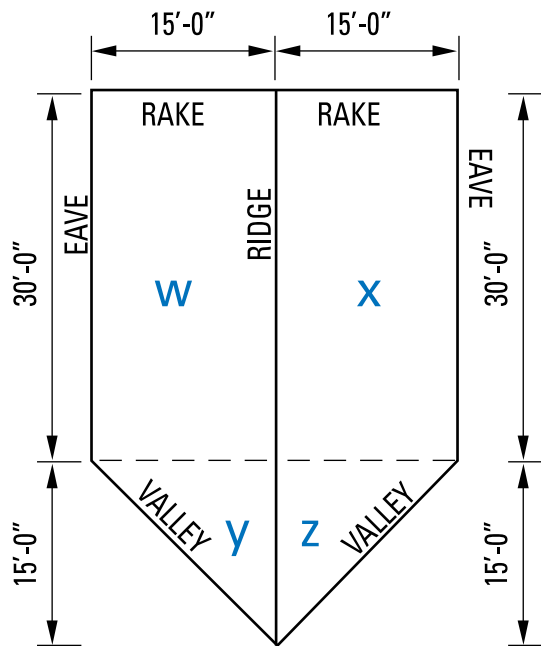

$$\text{Section C} = (450 + 112.5) \times 2 = 1,125 \text{ square feet.}$$

Section D

$$x = (15' \times 15')/2 = 112.5 \text{ square feet}$$

$$y = 10' \times 15' = 150 \text{ square feet}$$

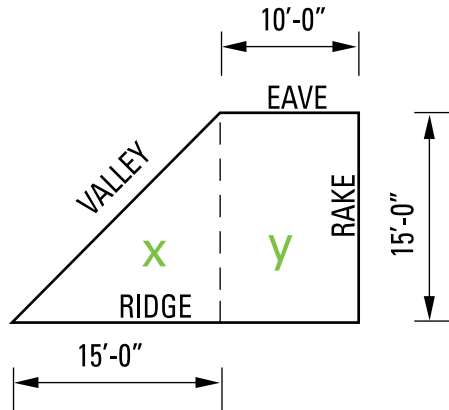

$$\text{Section D} = 112.5 + 150 = 262.5 \text{ square feet}$$

Section E

Because this section has several different subsections, it is important to double check the measurements in the sketch and to make sure that every piece is either rectangular or triangular.

$$s = (15' \times 15')/2 = 112.5 \text{ square feet}$$

$$t = 40' \times 15' = 600 \text{ square feet}$$

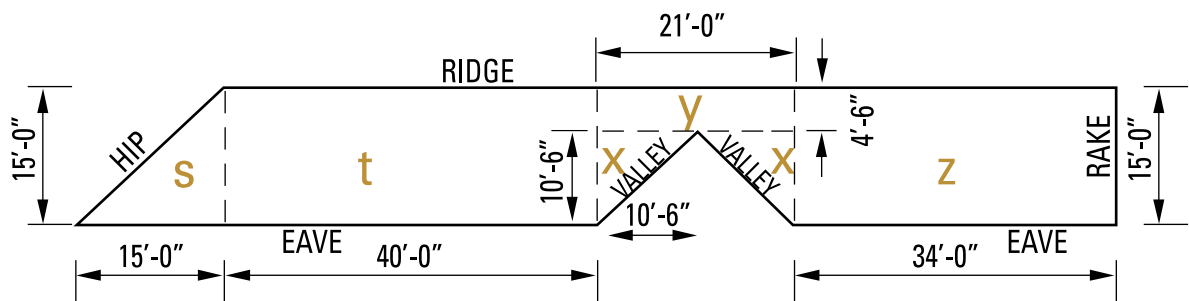

Both small triangles in the center part should be checked to make sure that they are the same size.

$$x = (10.5' \times 10.5')/2 = 55 \text{ square feet}$$

$$y = 21' \times 4.5' = 94.5 \text{ square feet}$$

The actual answer of x is $55\frac{1}{8}$ " square feet, but it has been rounded off for ease of measuring.

$$z = 34' \times 15' = 510 \text{ square feet}$$

Section E = $112.5 + 600 + 55 + 55 + 94.5 + 510 = 1,427$ square feet.

Section F

This section is a smaller version of Section C and should be calculated the same way.

$$w = (10.5' \times 10.5')/2 = 55 \text{ square feet}$$

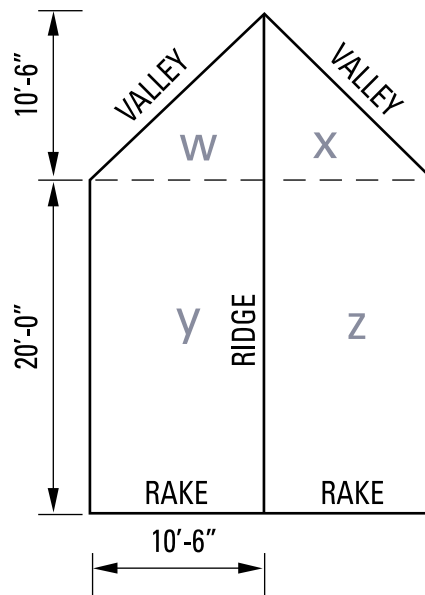

$$y = 20' \times 10.5' = 210 \text{ square feet}$$

Section F = $55 + 55 + 210 + 210 = 530$ square feet.

SUM IT UP

Adding up the subtotals from all sections:

Section A = 225

Section B = 1,050

Section C = 1,125

Section D = 262.5

Section E = 1,427

Section F = 530

Total square footage is equal to 4,619.5 square feet, or roughly 46 squares, since:

1 square = 100 square feet

The application of roofing requires trimming of shingles in valleys, roof penetrations and rake edges. Once the roof area is determined the amount of shingle material will need to be adjusted for the trimming. The increase in the amount needed to complete the roofing project will vary depending on the roof complexity. In most cases it should be between 2% and 10%.

ROOF SLOPE

Determining Your Roof's Slope

The slope of your roof is determined by the vertical rise in inches for every horizontal twelve-inch (12") length (called the "run"). It is expressed with the rise mentioned first and the run mentioned second. For instance, if your roof has a four-inch (4") rise for every horizontal foot, then it is said to have a 4" in 12" slope (4:12).

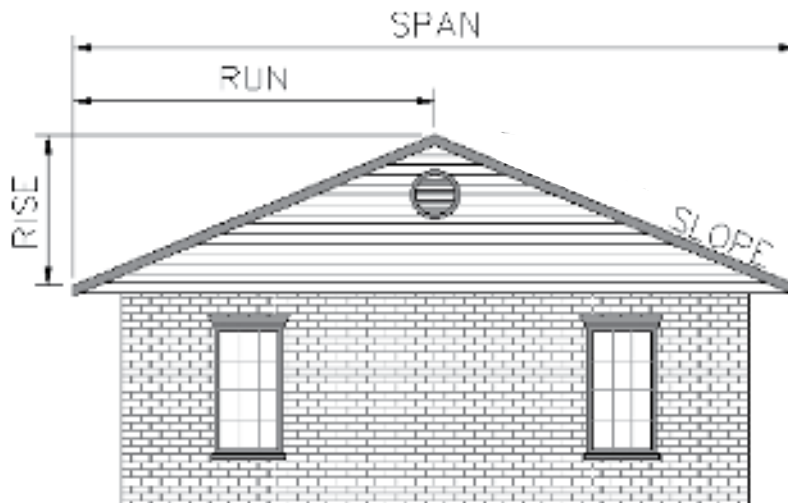

A fairly easy way to determine the slope is to use a 12" carpenter's level. Set one end on the roof surface and level the carpenter's level. Using a tape measure or a ruler, measure from the other end of the carpenter's level down to the roof surface. There are also free applications available for smartphones that include a slope indicator that may be used.

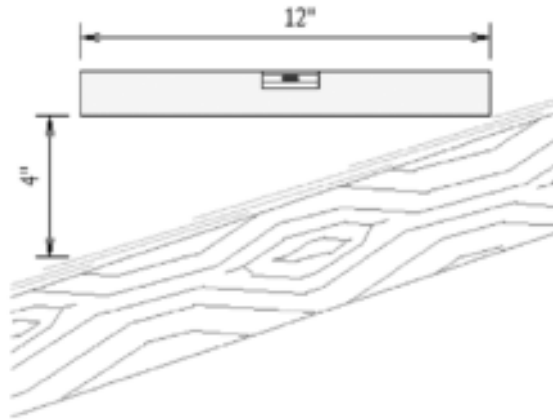

ADDITIONAL MATERIAL ESTIMATES

To complete the estimate, the required quantity of starter strips, drip edges, hip and ridge shingles, valley flashing and ventilation accessories must be determined. Each of these estimates depends on the length of the eave, rakes, hips, ridges and valleys at which the material will be applied.

Most roofing jobs require anywhere from 2% to 10% excess shingles due to trim waste. The amount of trim waste depends on how many valleys, dormers, hips and roof penetrations there are.

[Note]

The drawings and some of the descriptions found in “Estimating Area (Complex Roofs)” have been used courtesy of E. J. Sandquist, www.roofhelp.com.





CHAPTER 6

PREPARING FOR THE JOB

In addition to roofing materials, a number of accessories will be required for the job along with proper tools and fasteners. All material shall be neatly stored, elevated, and protected from damage due to wetness or freezing. At all times, workers should follow safe work practices that help prevent dangerous conditions and possible accidents.

[Note]

Follow all local building and zoning codes and ordinances.

SAFETY

The best form of accident insurance is accident prevention. Therefore, inspect each job site before the work begins for possible hazards such as overhead electrical lines or unstable ground conditions that might not adequately support ladders or scaffolding. Bring any potentially hazardous conditions to the attention of all workers before the job begins. Adhere to OSHA safety and fall protection standards and observe these general precautions (including, but not limited to):

- Personnel Protection Equipment: Safety glasses, cut-resistant gloves, knee protection, steel toe foot wear, hard hats, safety shoes, dust masks and an OSHA approved harness.
- Wear/use fall protection equipment as required by OSHA.
- Do not attempt to work in inclement weather, or on wet or damp roofs.
- Do not touch wires crossing over the roof. If cranes are used to raise materials, be sure the operator is aware of overhead power lines or other wires. Keep metal ladders away from power lines.
- Extension ladders should have proper locking devices and be in good condition. Place the ladders at safe angles on stable foundations and properly secure them to prevent movement. Ladders must extend above the edge of the roof by 3' minimum.
- The proper angle for ground ladders is for the base of the ladder to extend 1'-0" from the edge of the building for each 4'-0" of ladder height.
- Ropes should be used as safety lines for personnel. Anchor points should sustain the weight of the personnel.
- Ropes, bungee cords, or tensioning straps should be used to secure ground ladders to the roof edge.
- Avoid leaning away from a ladder to work. Move the ladder as required.
- Keep the area around the base of the ladder free from debris, tools, and materials.
- Do not concentrate bundles or rolls of roofing materials on the deck. Distribute them over the entire roof surface to spread the load evenly.
- As the work proceeds, keep the deck clear of unnecessary debris to avoid slipping and tripping hazards.
- Always use the proper tools for each segment of the roofing job.
- Remember — Safe roofing is no accident!



TOOLS

Prior to commencing work, it is suggested that the area surrounding the building be surveyed for low hanging wires, ground obstructions, and other items that might hinder the roofing operations. The following is a comprehensive list of tools that may be required to complete your roofing project. Not all tools may be necessary.

Ladders and/or Scaffolding

Used for access to the roof, for carrying materials up to the roof and for safe footing especially when working above grade, applying the starter strip and first course. Ladders and scaffolding must be carefully inspected prior to each use to identify any safety or structural issues. The user must also verify that the load rating for the ladder is adequate to sustain the loads of all users and supplies or equipment they may be carrying.

Bungee Cords or Tensioning Straps

Used to secure the top end of the ladder to the building via gutters or other appurtenances.

Tape Measure

Used for making measurements that will be required for an accurate and neat installation.

Carpenter's Pencil

Used to mark locations for snapping chalk lines, etc. Use carpenter's pencil if available due to durability of pencil lead.

Chalk Line

Used for snapping lines that will be utilized to guide the installation and to align the materials over the roof surface.

Roofing Knife

Used for cutting, shaping and fitting the various materials for an accurate, tight-fitting installation.

Hammer or Roofer's Hatchet

Used for all nailing that will be required. A roofer's hatchet may also be used for aligning shingles.

Power Nailer (pneumatic gun)

Pneumatic nailers are designed for a wide variety of applications. Not all are appropriate for the application of roofing shingles. Use only a tool specifically designed by the manufacturer for roofing. Use a tool designed to withstand the abrasive nature of roofing materials and that has features to speed and facilitate the roofing material application. Pneumatic nailers for roofing are adjustable to achieve proper depth of nail drive. Correct depth of drive may be achieved by a particular tool through one or more of the following methods as recommended by the tool manufacturer:

- Air pressure control
- Selection of proper length driver (driver blade - striker)
- Use of a choke on the tool exhaust system
- Outfit a tool with manufacturer approved components such as piston bumper shims, flush drive attachments, and specially-sized variations of standard tool components. Through repeated contact with the shingles, a buildup of asphalt will occur on the nose of the tool. The installer must periodically clean the tool, or otherwise compensate for this buildup, or fasteners will be underdriven. Cleaning is usually accomplished with environmentally safe solvents applied for immediate removal or overnight soaking of only the nose of tool.

Putty Knife, Pointed Trowel, Caulking Gun, or Brush

Used for applying asphalt cements.

Chisel and Saw

Used for repairing or replacing damaged decking.

Flat Shovel

Used for removing shingles in reroofing applications. A special shingle-removing tool may also be used.

Tin Snips

Used for cutting metal such as drip edge and flashing for valleys, and side and front walls.

Push Broom

Used for sweeping the roof deck prior to installing any type of underlayment and for cleaning up after removing old shingles or after the completed roofing application.

Magnetic Roller

Used for picking up nails after the job is completed around the job site.



Tarps

Used to cover shrubs and protect the landscape around the home from debris that may fall from the roof or portions of the roof that may not be completed.

1"x4" or 2"x4" Cleats

Used to secure tarps to roof for temporary roof covering.

Cell Phone

Used to call 911 in the event an accident occurs.

CHAPTER 7

DECK PREPARATION — NEW CONSTRUCTION

No roof is better than the quality of its installation. Asphalt roofing materials are no exception. They are designed to give many years of service when applied carefully and correctly.

UNDERLAYMENT

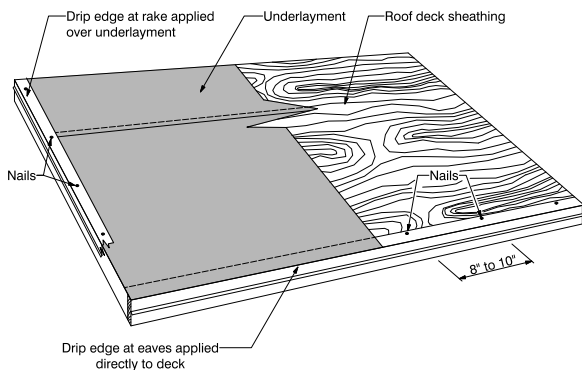

Figure 7-1
Application of underlayment

After the deck has been properly prepared and dried, cover it with the appropriate underlayment. Most building codes have specific requirements for underlayment, ice dam protection, or both. These code requirements must be followed. Where permissible, follow the ARMA recommendations that follow.

Historically, asphalt-saturated felt products have been specified for use as underlayment. However, there are now many synthetic underlayments available that may or may not be self-adhering. Ambient temperature conditions may warrant the use of a synthetic underlayment with or without a self-sealing feature or a self-adhering shingle underlayment (a type of modified bituminous sheet material). Underlayment material used beneath roofing shingles is typically required to comply with one of the following standards: ASTM D226, ASTM D4869, ASTM D6757, ASTM D1970, or CSA A123.2 and A123.3. Consult local codes and/or shingle manufacturer's recommendations for specific material standards.

On decks having a slope of 4" per foot (4:12) or greater, one layer of non-perforated underlayment should be applied. The use of asphalt-coated base sheets, self-adhering shingle underlayments, polyethylene sheets or laminated waterproof papers could result in vapor retardation — trapping moisture or frost between the covering and the roof deck when the deck is not properly ventilated. Consult with the individual manufacturer for specific recommendations when using these types of products.

[Note]

The underlayment application figures in this chapter show the proper use of drip edges. Drip edges should be used on all roof rake and eave edges. Drip edge installation is covered in Chapter 3.

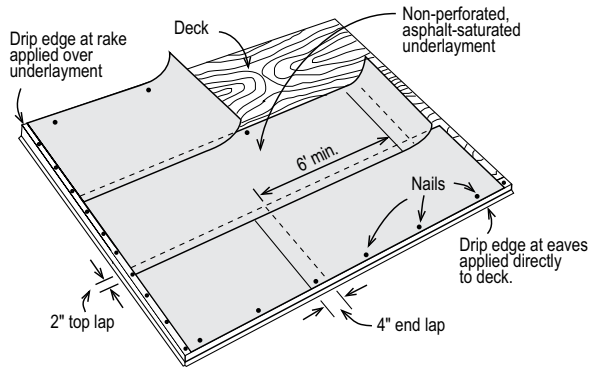

Figure 7-2
 Application of felt underlayment on slopes
 4:12 or greater

Overlap and fastener requirements of synthetic underlayments may vary and the minimum overlaps as specified by the manufacturer should be followed. Check with your local codes for specific underlayment and fastener requirements. Always lay the underlayment courses parallel to the eaves, lapping each course at least 2" over the underlying course. Underlayment should not run perpendicular to the eaves. Secure the underlayment with roofing nails or cap nails to hold it in place for safety reasons. (See Figure 7-2) Nails should be driven straight and flush with the surface. If two or more pieces are required to continue a course, lap the ends at least 4". End laps in a succeeding course should be located at least 6' from end laps in the preceding course. Lap the underlayment a minimum of 6" from both sides over all hips, ridges and valleys. Where the roof meets a vertical surface, carry the underlayment at least 4" up the surface.

Underlayment should always be used in new construction as it provides many benefits to the system.

Important reasons for installing underlayment when applying shingles over wood decks include:

- Underlayment is water-resistant and provides secondary protection in conjunction with the shingles to shield the deck from wind-driven rain and to prevent water from reaching the deck.
- Underlayment keeps the deck dry until shingles are applied, minimizing problems that may result if shingles are placed on wet decks. Shingles should be applied as soon after the application of the underlayment as possible.
- Underlayment installed together with code-compliant decking materials, shingles and the proper type and number of fasteners results in a roof assembly having either a Class A or Class C fire classification. A shingle by itself doesn't carry a fire classification; rather, it is a component of a classified roof assembly. Building codes and local ordinances prescribe conditions under which Class A roof assemblies are required.
- Installing underlayment helps reduce "picture framing" (the visible outline of deck panels caused by irregularities in roof decking thicknesses).
- Underlayment offers protection to the shingles from resins that may come from wood based sheathing.

Proper application techniques should be followed to ensure optimum performance of underlayments.

EAVE FLASHING FOR ICE DAM PROTECTION

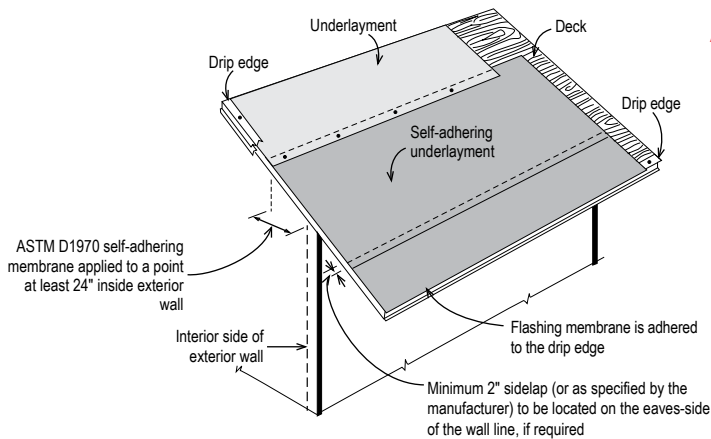

Figure 7-3
Application of self-adhering shingle underlayment for eave flashing

Ice dams are formed by the continual thawing of snow over the warmer portions of the roof and refreezing over the cold eave. The ice dams can cause the backing up of water and slush under the exposed roofing material and subsequent damage to the structure. Eave flashing is recommended when applying roofing material to this potentially vulnerable area to help prevent such water penetrations. In climates where icing along the eaves is anticipated or where the average January temperature is 25°F or less, eave flashing must be installed to ensure maximum protection against ice damming damage. Selection of the appropriate flashing material and the flashing strip width will depend upon the roof slope and the severity of icing conditions anticipated, as well as local building code requirements.

The recommended method is to use self-adhering shingle underlayment that complies with ASTM D1970, or as approved by the shingle manufacturer or local code. The self-adhering shingle underlayment is applied directly to the deck and is applied at a width to extend up the roof from the eaves or rake edge to a point at least 24" inside the interior wall line (heated space). If the membrane is not wide enough to reach that point, install additional course(s) of membrane as needed, overlapping the previous course by 2" or as specified by the manufacturer.

[Note]

When a self-adhering shingle underlayment is used as underlayment, no additional eave flashing application is required.

Self-adhering shingle underlayments are also excellent for use as flashings on ridges, hips and valleys, as well as around penetrations, dormers, skylights and chimneys. Because most eave flashing materials are vapor retarders, they should not be used beyond recommended areas without proper ventilation. A lack of proper ventilation in these cases will result in the possibility of water vapor condensation under the roof deck.

VALLEY UNDERLAYMENT AND FLASHING

Valleys are formed where two sloping roof planes meet at an angle. The sloping planes direct water toward the valley, concentrating the drainage along the joint and making it especially vulnerable to leakage. As a result, one of the most important installation details for good roof performance is proper valley flashing. Consult the appropriate roofing manufacturers for recommendations on a particular application.

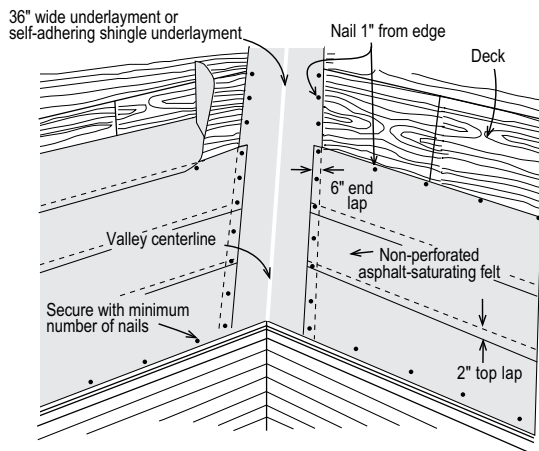

Figure 7-4
 Typical application of underlayment in a valley

To install underlayment in a valley, first center a 36" wide strip of the appropriate underlayment in the valley and secure it with only enough nails to hold it in place or place a 36" wide strip of self-adhering shingle underlayment directly to the deck. Then trim the horizontal courses of felt underlayment applied on the roof to overlap the valley strip at least 6" (See Figure 7-4). In all valleys the underlayment or self-adhering shingle underlayment should lay tight to the valley juncture in the valley but should not be creased or wrinkled.

Following application of the underlayment, roofs with multiple planes require the construction of one of three types of valleys: open, woven or closed cut. Regardless of the type of valley used, it must be smooth, unobstructed, of sufficient capacity to carry water away rapidly and capable of withstanding occasional backing up of water.

A. Open Valleys

Figure 7-5 illustrates a method of flashing asphalt shingle roofs. The type of flashing shown is an open valley where some of the flashing is exposed to view. The recommended flashing material is a preformed W valley consisting of 0.0179" (26-gauge) galvanized sheet steel or an equivalent corrosion resistant, non-staining material of the appropriate thickness (check with shingle manufacturer and local code). Crease valleys can be used but the preferred valley is the preformed W metal flashing. The width should be no less than 24", but local building codes or shingle manufacturer may require a greater width.

If the valley is covered with a minimum 36" wide self-adhering shingle underlayment that complies with ASTM D1970, adhered directly to the deck, the valley is ready for the metal valley flashing. If the valley is covered with felt underlayment, an additional layer of #50 felt or heavier valley underlayment is required before the metal flashing is applied. Center the strip in the valley, securing the non-self-adhering materials with only enough nails to hold it in place. Nail the strip along a line 1" from the edges, first on one edge all the way up, then on the other while pressing the flashing strip firmly and smoothly into the valley. Laps should be 12" and cemented.

Center the metal flashing in the valley. Trim the lower edge flush with the eaves drip edge. Install it up the entire length of the valley. If two or more strips of flashing are required, lap the upper piece over the lower so that drainage will be carried over the joint, not into it. The overlap should be 12" and fully bonded with asphalt roofing cement.

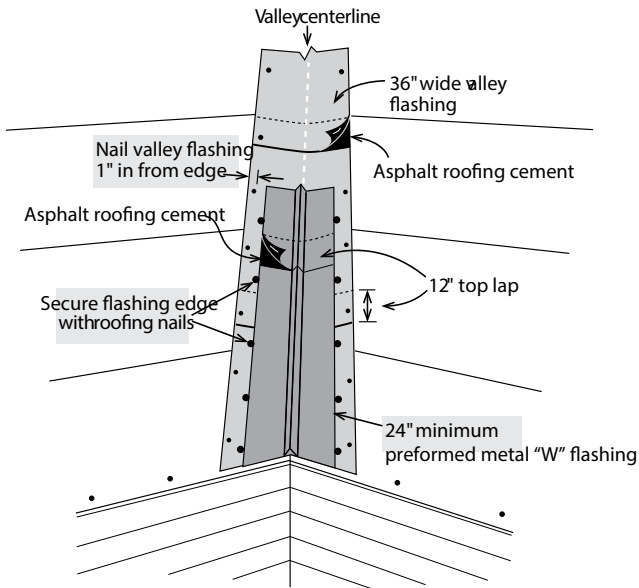

Figure 7-5
Application of corrosion resistant metal as flashing for an open valley
(The figure shows #50 or heavier felt for the valley flashing.)

Secure the valley metal to the roof deck without puncturing the deck, with roofing nails spaced 8"-12" apart. The valley will be completed with shingle application.

B. Woven and Closed Cut Valleys

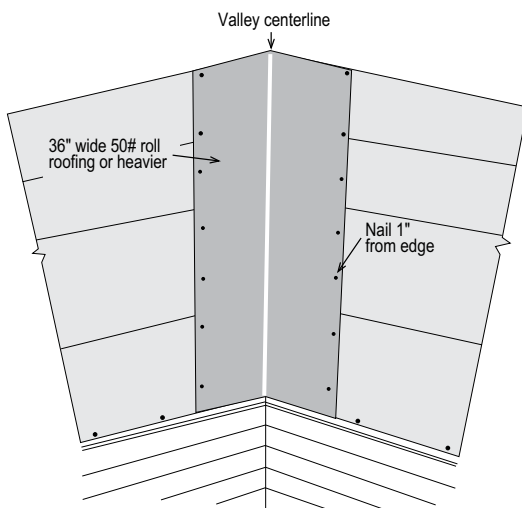

Figure 7-6
Application of flashing for a woven or closed cut valley

Figure 7-6 illustrates a closed cut valley which may be used where intersecting roofs are of the same slope and where it is desirable to conceal the flashing. If self-adhering shingle underlayment that complies with ASTM D1970 is adhered directly to the deck as shown in Figure 7-4 then no additional valley flashing is required. If the valley is covered with felt underlayment as shown in Figure 7-4, cover the valley with a minimum 36" wide strip of roll roofing, #50 or heavier. Center the roll roofing strip in the valley, securing the materials with only enough nails to hold it in place. Nail the strip along a line 1" from the edges, first on one edge all the way up, then on the other while pressing the flashing strip firmly and smoothly into the valley. Laps should be 12" and cemented. The valley will be completed as the shingles are installed. When installing a closed-cut valley installation, weave the first course.

CHALK LINE

The dimensional variations of individual strip shingles are seldom significant, but on a large expanse of roof, the accumulated effect of these slight variations could result in diverging butt lines or misaligned cutouts. Whether there is a large expanse of roof or a small one, chalk lines provide visible guides that help ensure the application of the shingles in proper horizontal and vertical alignment with the proper exposure and the intended coverage. Never vary the shingle exposure between courses by more than $\frac{1}{8} \pm$ ", as this deviation may negatively affect roof performance and aesthetics. Shingle sides should be butted, but not forced together, to maintain adequate shingle coverage.

To place a horizontal chalk line parallel to the eaves, measure the appropriate distance on the roof and mark it at three locations — at each end and in the middle as a check against possible measurement errors. Put a nail on the mark at each end, stretch the chalk line between them and pull it taut. Check the alignment of the middle mark, and then snap the line from the center.

Vertical chalk lines are important for aligning cutouts on shingles that are designed to create a pattern from eaves to ridge. They are especially important for aligning shingles on each side of a dormer so that when the application of shingles passes it, the shingles and cutouts meet above the dormer in proper alignment without any gaps or overlaps.

On long runs, snap a vertical chalk line in the center of the run and apply shingles to the left and right of the line. Check horizontal chalk lines as the shingle application approaches the ridge so that the upper courses will be parallel to it.

CHAPTER 8

APPLICATION OF STRIP SHINGLES ON NEW CONSTRUCTION

Asphalt roofing products are probably the easiest of all roofing materials to install. Even so, there are certain procedures that must be followed to ensure the quality of the installation and of the roof covering itself. These include not only underlayment installations, but also alignment techniques and starter strip applications as well as various methods of applying the first and successive courses, fastening the materials to the deck and finishing the hips and ridges. All of these points are discussed below in the order they would be encountered in the field.

Before beginning application of asphalt shingles, it is prudent to review the applicable building codes for specific application requirements. Some building codes have specific application requirements. The requirements of these codes must be followed. Where allowed, the ARMA recommendations that follow represent good roofing practice, but not necessarily the only acceptable method(s) of application.

SHINGLE APPLICATION

While the general application procedures for all asphalt strip shingles are essentially the same, differences do exist in applying the first shingle in each course and, depending upon the number of cutouts in the strip, in fastening the shingles. Thus, it is necessary to follow the shingle manufacturer's application instructions as printed on the shingle bundle wrapper.

Prior to shingle application, check that all chimneys are completed and all vent pipes, soil stacks and ventilators are in place. Make provisions for the additional flashings that may be required as the shingles are applied, such as those around chimneys and stacks and at vertical wall joints.

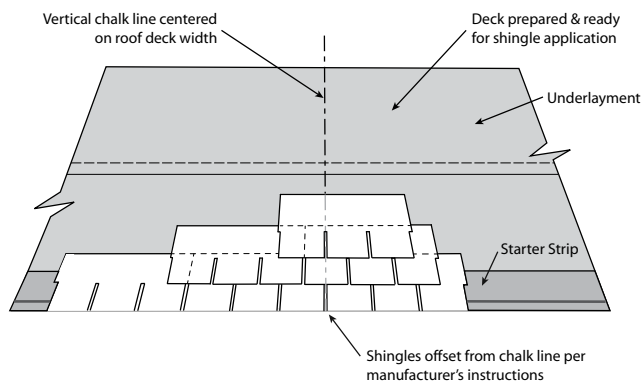

Figure 8-1
Application from roof centerline

[Note]

The release tape found on the reverse side of the shingles prevents the shingles from sticking together in the package. It should not be removed during application.

Apply the shingles across and diagonally up the roof. This will ensure that each shingle is fastened properly. Straight-up application or “racking” may result in less than the recommended number of nails being used because of the manner in which the shingles have to be applied. “Racking” requires that part of the shingles in some courses be placed under those already applied in the course above. Because part of the shingle is hidden, it may be overlooked when the shingle is fastened. With a diagonal application up the roof, each shingle is completely visible until covered by the course above. Racking may accentuate shading tendencies as well. Some shingle products are designed to be installed in a rack fashion. Consult the manufacturer for instructions on specifics.

A. Starter Strip

The starter strip may be either a row of shingles trimmed to the shingle manufacturer’s recommendations or a strip of mineral-surfaced roll roofing at least 2" wider than the shingle exposure. Pre-cut starter shingles are also available. The starter strip protects the roof by filling in the spaces under the cutouts and joints of the first course of shingles. It should overhang the eaves and rake edges by ¼" to ¾". Where the drip edges extend out from the eaves and rakes, the shingles may be cut flush with the drip edge. The line of sealant on the starter strip must be positioned near the eave edges.

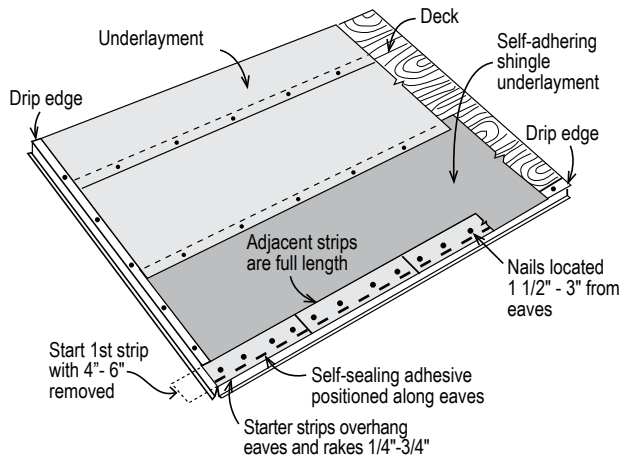

Figure 8-2
 Application of starter strip

[Note]

Overhang will depend on the drip edge use. The diagram shows a 90 degree drip edge. Refer to Chapter 3, pg 21.

If self-sealing shingles are used for the starter strip, remove the tab portion of each shingle and position the remaining strip with the factory-applied adhesive face up with the adhesive strip nearest the lower edge of the eaves. Trim 4" - 6" from the end of the first shingle in the starter strip. Install the fasteners on the starter strips parallel to the eaves along a line 1½"-3" above the eaves. Position the fasteners so that they will not be exposed under the cutouts in the first course. Manufacturers may require different starter strip techniques or provide starter strip materials that require specific application instructions.

B. First and Succeeding Courses

The first course is the most critical. Be sure it is laid perfectly straight, checking regularly during application against a horizontal chalk line. A few vertical chalk lines aligned with the ends of shingles in the first course will ensure proper alignment of cutouts.

The first course starts with a full shingle while succeeding courses start with portions removed according to the style of shingle being applied and the pattern desired. Do not discard the pieces cut from the first shingle in each course. If full tabs, they may be useful for finishing the opposite end of the course or for hip and ridge shingles.

To obtain the correct exposure for square-tab strip shingles, align the butts with the top of the cutouts in the course below. Install no-cutout shingles and those with variable butt lines according to the manufacturer's directions to obtain correct exposure.

There are three typical offset methods of applying standard three-tab strip shingles (i.e. 36" long, 5" exposure): the six-inch offset method, five-inch offset method and four-inch offset method. These methods correspond to the additional amount removed from the first shingle in each successive course to obtain a desired pattern.

C. The 6-Inch Offset Method

The six-inch offset method, illustrated in Figure 8-3, starts each succeeding course after the first and up to the sixth with a shingle from which an additional 6" has been removed. Thus, the first course starts with a full length shingle. The second course then starts with a shingle that has 6" removed and so on through the sixth course which starts with a shingle that has 30" removed. Adjacent shingles in each course are all full length. The seventh course again starts with a full length shingle and the pattern is repeated every sixth course. When using the six-inch offset method, nominal tolerances in shingle length may affect tab alignment.

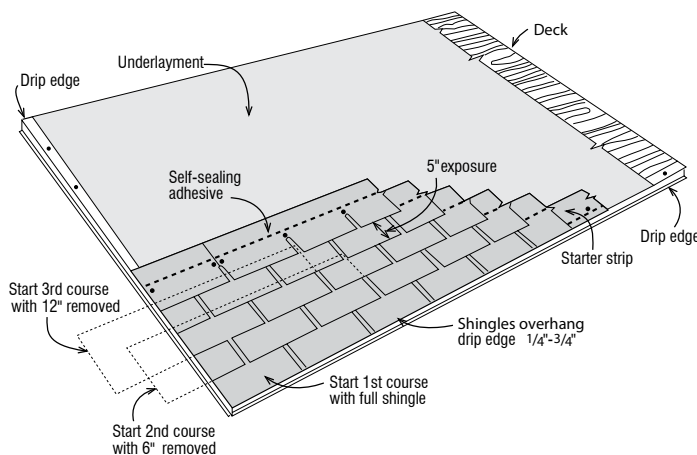

Figure 8-3
Application of shingles using the
6-inch offset method

[Note]

Never use an alignment system where shingle joints are closer than 4" to one another. Consult the manufacturer's installation instructions for specifics on offset requirements. High wind areas and high slope applications typically require specific nailing and offset. Consult local codes for specifics.

D. The 5-Inch Offset Method

With the five-inch offset method of application, illustrated in Figure 8-4, the first course begins with a full shingle. The second through seventh courses have an additional 5" removed from the first shingle in each course; therefore, the second course starts with 5" removed from the first shingle, the third course with 10" removed from the first shingle and so on through the seventh course which has 30" removed from the first shingle. Adjacent shingles in each course are full length. Proceed with additional courses to continue the 5" offset pattern.

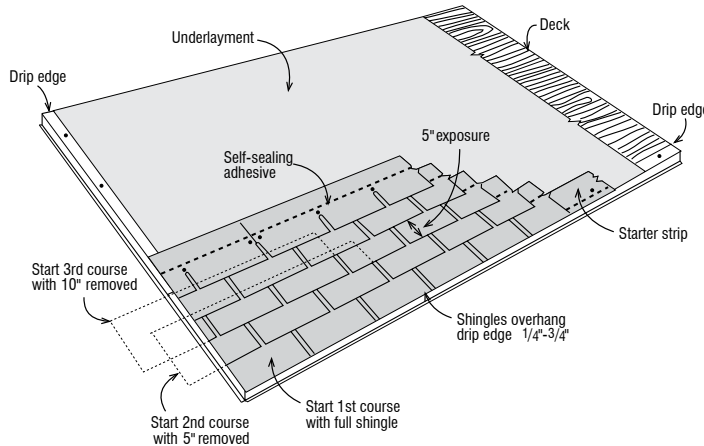

Figure 8-4
 Application of shingles using the 5-inch offset method

[Note]

The eighth course does not begin with a shingle that has 35" removed because the remaining 1" width does not lend itself to proper fastening.

E. The 4-Inch Offset Method

The four-inch offset application method is illustrated in Figure 8-5. Start the first course with a full shingle. Start the second course with 4" removed from the first shingle, the third course with 8" removed, and so on through the ninth course which has 32" removed from the first shingle. Adjacent shingles in each course are full length. The tenth course again begins with a full length shingle and the pattern is repeated every ninth course.

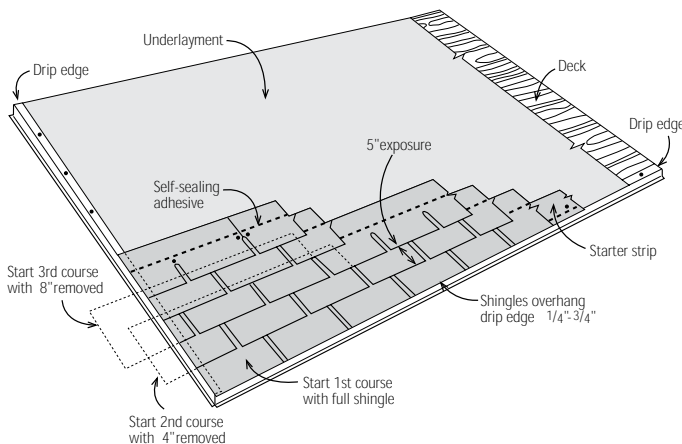

Figure 8-5
 Application of shingles using the 4-inch offset method

VALLEYS

Several different methods of treating valleys are possible including the open, woven and closed cut methods. Woven or closed cut valleys are the preferred treatment for strip shingles. Open valleys are preferred for individual interlocking type shingles, as the nails required for woven or closed cut construction might be placed at or near the centerline of the valley. For all the methods, valley flashing (Chapter 7) should be in place before shingle application is begun except for open valleys around dormers where the valley flashing must overlap the top courses of shingles along the dormer sidewalls. Thoroughly working all valley materials well into the break of the valley prior to fastening is recommended, to avoid inadvertent foot traffic damage to the valley materials. Care should be exercised to prevent scratching or scoring of the valley metal.

A. Open Valleys

Snap two chalk lines, one on each side of the valley centerline, over the full length of the valley flashing as shown in Figure 8-6. Locate the upper ends of the chalk lines 6" apart at the ridge (i.e., 3" to either side of the valley centerline). The lower end of the chalk lines should diverge from each other $\frac{1}{8}$ " per foot of the valley length. For an 8' long valley, the chalk lines should be 7" apart at the eaves; for a 16' valley, they should be 8" apart. The minimum shingle overlap on each side of the metal valley is 6". It's optional to use the W or inverted V.

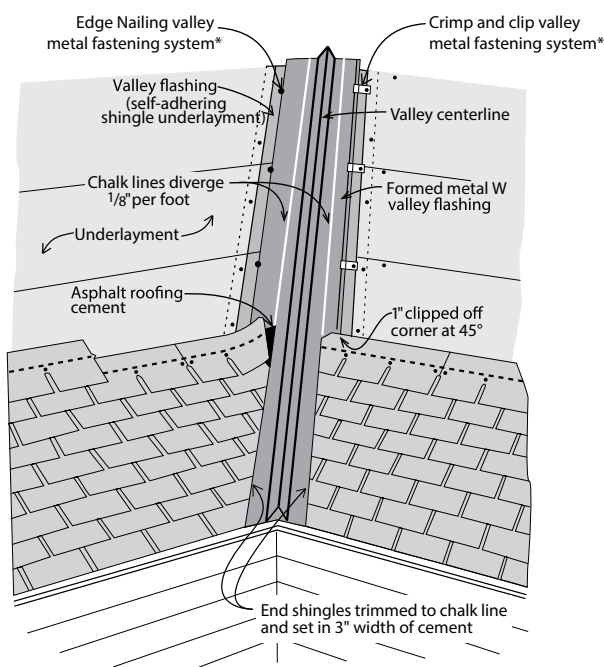

Figure 8-6
Application of shingles in an open valley

* Two acceptable methods for valley metal fastening.

As shingles are applied toward the valley, trim the last shingle in each course to fit on the chalk line. Never use a shingle trimmed to less than 12" in length to finish a course running into a valley. If necessary, trim a tab off the adjacent shingle in the course to allow a longer portion to be used. Clip 1" from the upper corner of the shingle on a 45° angle to direct water into the valley and prevent it from penetrating between the courses. Finally, to form a tight seal, cement the shingle to the valley lining with a 3" width of asphalt roofing cement (conforming to ASTM D4586). There should be no exposed nails along the valley flashing.

B. Open Valleys for Dormer Roofs

Figure 8-7 illustrates that the valley between a dormer and main roof requires special treatment. Do not install valley flashing until the shingle application reaches a point just above the lower end of the valley.

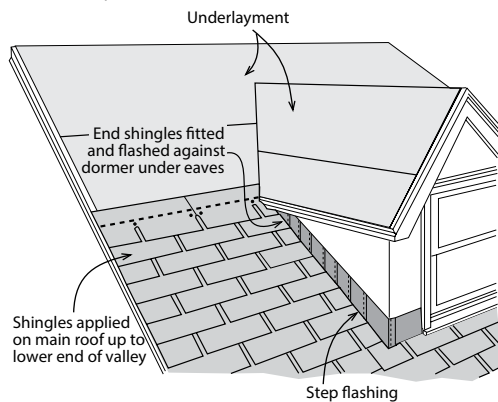

Figure 8-7
 Point at which installation of open valley at dormer roof begins

Apply the first or bottom layer of valley flashing as shown in Figure 8-8. Trim the lower section of the flashing so that it extends a minimum of ¼" below the edge of the dormer deck. The lower section in contact with the main roof deck should project at least 2" below the point where the two roofs meet. Extend the upper section so that the portion on the main roof extends 18" above the point where the dormer intersects the roof. Trim the portion on the dormer at the ridge.

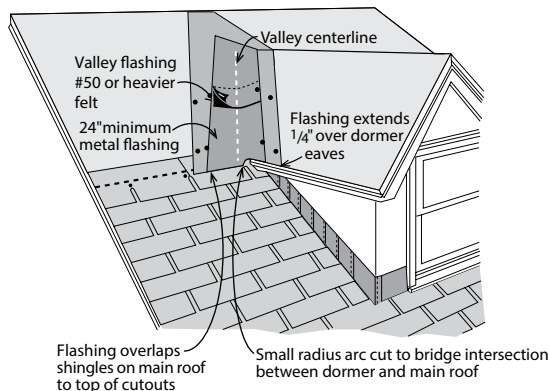

Figure 8-8
 Application of flashing for an open valley at a dormer roof

[Note]

If a roof surface is broken by a dormer or valley, start applying the shingles from a rake and work toward the break. If the surface is unbroken, start at the rake that is most visible. If both rakes are equally visible, start at the center and work both ways. On hip roofs, start at the center of the roof surface and work both ways. Snap a vertical chalk line in the center of the roof surface to work from in either direction.

Apply valley flashing on the other side of the dormer in the same manner, extending the portion on the main roof up and over the portion from the first valley. (Apply the 36" wide valley flashing in the same manner as any open valley flashing.)

[Note]

See Chapter 9 on how to use self-adhering shingle underlayment for valley flashing on open valleys for dormer roofs.

Trim the second or top layer of flashing (24" minimum width non-corrosive metal valley flashing) on the dormer side to match the lower end of the underlying strip. Trim the side that will lie on the main deck to overlap the nearest course of shingles. This overlap is the same as the normal lap of one shingle over another for the shingles being applied. For example, three-tab strip shingles, extend to the top of the cutouts or for laminates extend to the top of the shingle exposure.

Nail the top flashing strip over the bottom as in standard open valley construction. Work the flashing into the valley joint so that it lies flat and smooth in both planes to the edge of the dormer eaves. Trim the top layer horizontally on a line with the top of the dormer ridge where it intersects the main roof.

Apply the top layer in the valley on the other side of the dormer in the same manner except at the dormer ridge where it is cemented and nailed to the first valley flashing.

Trim the lower end of the flashing on a small radius arc that bridges slightly over the point of intersection between the dormer and main roof. This shape forms a small canopy over the joint between the two decks.

Snap chalk lines on the valley flashing 3" on each side of the centerline at the top and diverging $\frac{1}{8}$ " per foot to the bottom of the valley. Resume the shingle application, trimming the end shingle in each course to the chalk lines. Clip the upper corner and embed the end shingle in a 3" wide strip of asphalt roofing cement (conforming to ASTM D4586) to seal it to the flashing. Complete the valley construction in the usual manner. (See Figure 8-9)

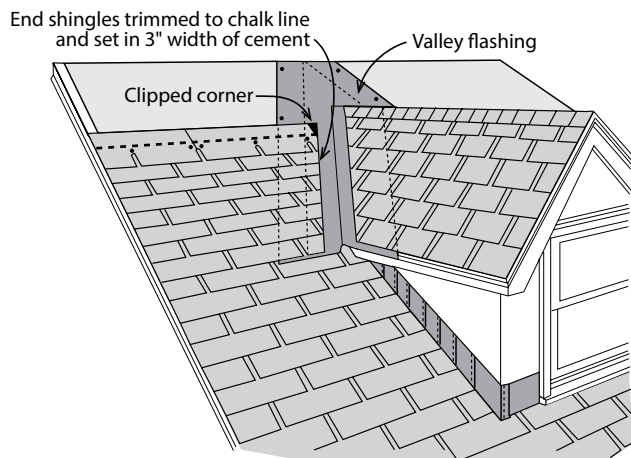

Figure 8-9
Shingle application in an open valley at dormer roof

After shingles have been applied to both sides of the dormer roof, apply the dormer ridge shingles. Start at the front of the dormer and work toward the main roof. Apply the shingles as described later in this chapter in the section on “Hips and Ridges.” Apply the last ridge shingle so that it extends at least 4" onto the main roof. Slit the center of the portion attached to the main roof and nail it into place. Then apply the main roof courses to cover the portion of the last ridge shingle on the main roof. Snap chalk lines so that the shingles on the main roof will continue the same alignment pattern on both sides of the dormer as shown in Figure 8-10.

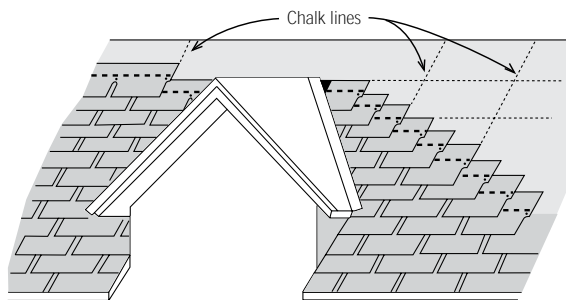

Figure 8-10
Proper alignment of shingles and cutouts
above dormer using chalk lines

C. Closed Cut Valleys

[Note]

The first course and only the first course of shingles from the intersecting roof surface should be woven with the first course of shingles on the starting roof.

With valley flashing already in place, apply the first course of shingles along the eaves of one of the intersecting roof planes and across the valley. The first course and only the first course of shingles from the intersecting roof surface should be woven with the first course of shingles on the starting roof. For proper flow of water over the trimmed shingle, always start applying the shingles on the roof plane that has the lower slope or lesser height. Extend the end shingle at least 12" onto the adjoining roof as shown in Figure 8-11. Do not make a joint in the valley. If a shingle falls short, add in a one or two tab sections so that the joint occurs outside the line of the valley. Apply succeeding courses in the same manner, extending them across the valley and onto the adjoining roof. Press the shingles tightly into the valley.

Use normal shingle fastening methods except that no fastener should be within 6" of the valley centerline and two fasteners should be placed at the end of each shingle crossing the valley.

Snap a chalk line 2" from the centerline of the valley on the unshingled side. Then apply shingles on the unshingled side. Trim the shingles as they are being installed to the chalk lines and to ensure a neat installation. Trim 1" on a 45° angle from the upper corner of each end shingle upon installation. This will direct water into the valley. Finally, embed the end of each shingle in a 3" wide strip of asphalt roofing cement.

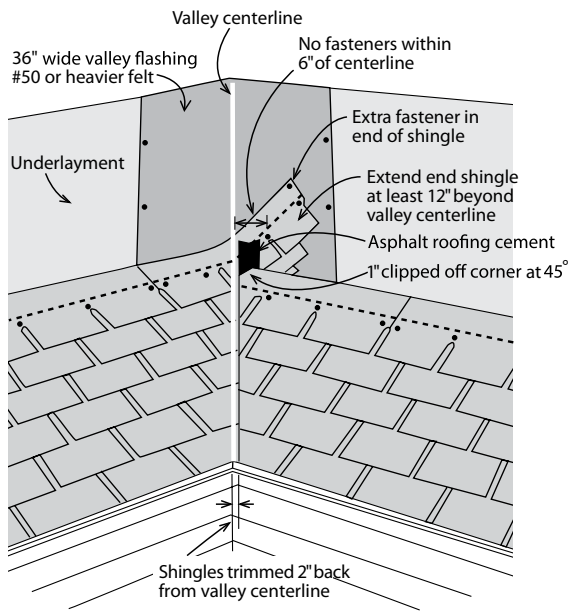

Figure 8-11
Shingle application in a closed cut valley

D. Woven Valleys

The valley flashing should already be in place as described earlier. Shingles on the intersecting roof surfaces may be applied toward the valley from both roof areas simultaneously or each roof area may be worked separately up to a point about 3' from the center of the valley and the gap closed later.

Regardless of which procedure is followed, apply the first course along the eave of one roof area up to and over the valley with the last shingle extending at least 12" onto the intersecting roof. Then apply the first course onto the intersecting roof along the eave and extend it across the valley over the top of the shingles already crossing the valley and at least 12" onto the other roof surface. Apply successive courses alternately from the adjoining roof areas, weaving the valley shingles over each other as shown in Figure 8-12. Press each shingle tightly into the valley and follow the same nailing procedures as the closed cut valley.

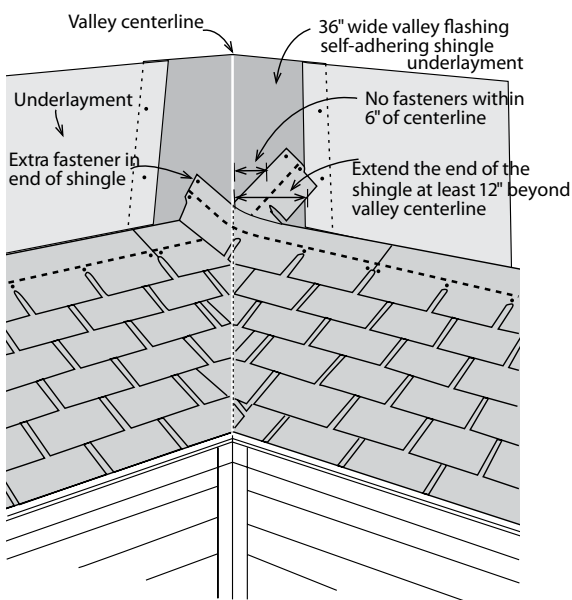

Figure 8-12
Shingle application in a woven valley





CHAPTER 9

APPLICATION OF LAMINATED SHINGLES ON NEW CONSTRUCTION

No roof is better than the quality of its installation. Laminated shingles are no exception. Like strip shingles, they are designed to give decades of service when applied carefully and correctly. In general, laminated shingles are applied similarly to strip shingles; however, they provide a three-dimensional appearance. Unlike strip shingles, laminated shingles are made up of one or more layers of tabs resulting in greater thickness and depth.

SHINGLE APPLICATION

While the general application procedures for all asphalt laminated shingles are essentially the same, differences do exist depending upon the product dimensions, exposure, and product design. Thus, it is necessary to study and follow the shingle manufacturer's application directions as printed on the shingle bundle wrapper.

Before beginning to apply shingles, check that all chimneys are completed and all vent pipes, soil stacks and ventilators are in place (See Chapter 10 for flashing and roof penetration details). Also make provisions for the additional flashings that will be required as the shingles are applied, such as those around chimneys and stacks and at vertical wall joints.

If a roof surface is broken by a dormer or valley, start applying the shingles from a rake and work toward the break. If the surface is unbroken, start at the rake that is most visible. For hip roofs and where both rakes are equally visible, start from the center and work both ways.

[Note]

The release tape found on the shingles prevents the shingles from sticking together in the package. It should not be removed at any time.

No matter where the application begins (left edge, right edge, or center), apply the shingles across the roof deck with designated course offsets resulting in a diagonal application pattern. If vertical shingle application is being considered (referred to as racking) refer to shingle manufacturer's requirements. Horizontal application is preferred and will ensure that each shingle is fastened properly.

A. Starter Strip

The starter strip may be either a row of shingles trimmed to the shingle manufacturer's recommendations or pre-cut starter shingles and starter shingle rolls. The starter strip protects the roof deck from wind-driven rain by filling in the spaces under the shingle joints of the first course of shingles. It also protects the first course of shingles from peeling back when exposed to high winds. It should overhang the eaves and rake edges by $\frac{1}{4}$ " to $\frac{3}{4}$ ".

Where the drip edge extends out from the eaves and rakes, the shingles may be cut flush with the drip edge or extend out no more than $\frac{3}{4}$ ".

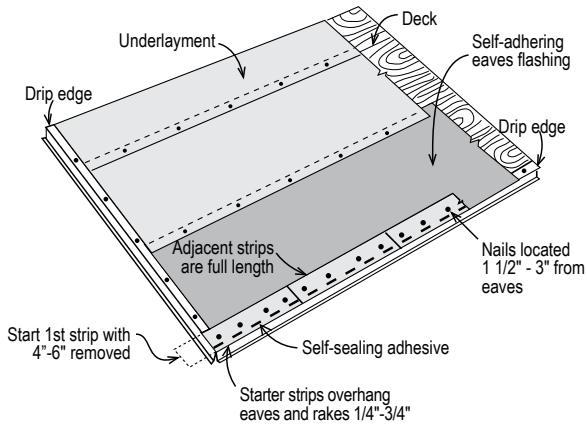

Figure 9-1
 Application of starter strip

[Note]

Overhang will depend on the drip edge use. The diagram shows a 90 degree drip edge. Refer to Chapter 3, pg 21.

If self-sealing shingles are used for the starter strip, remove the tab portion of each shingle and position the remaining strip with the factory applied adhesive face up with the adhesive strip nearest the lower edge of the eaves. Trim 4" - 6" from the end of the first shingle in the starter strip. Install the fasteners on the starter strips parallel to the eaves along a line 1½"-3" above the eaves edge ensuring the fastener enters a solid decking. Manufacturers may require different starter strip techniques or provide starter strip materials that require specific application instructions.

[Caution]

Excessive use of asphalt roofing cement may cause blistering.

B. First and Succeeding Courses

Proper application of the first course of shingles is the most critical. Be sure it is laid out perfectly straight; check against the chalk lines to ensure proper alignment of subsequent courses. Shingles should be installed so that shingle ends are offset. The first course typically starts with a full shingle, but individual laminated shingle manufacturers will have specific instructions for beginning the first course of shingles. As a general rule, shingle ends should be offset from the course above and below by at least 4". Make sure that no end joint is less than 2" from any nail in an underlying course. Begin nailing from the end nearest the shingle just laid, and proceed across, aligning each shingle carefully.

For best appearance and shingle function, the manufacturer's application instructions for shingle offsets and repeat pattern must be followed as indicated on the shingle wrapper. Each manufacturer has determined the optimum application pattern (for function and appearance) for each of their products.

APPLYING THE SHINGLES

The first course typically starts with a full shingle, while succeeding courses start with portions removed according to the style of shingle being applied. By removing different amounts from the first shingle in each course, shingle joints or multiple thickness areas in one course do not line up directly with those of the course below, creating the desired pattern.

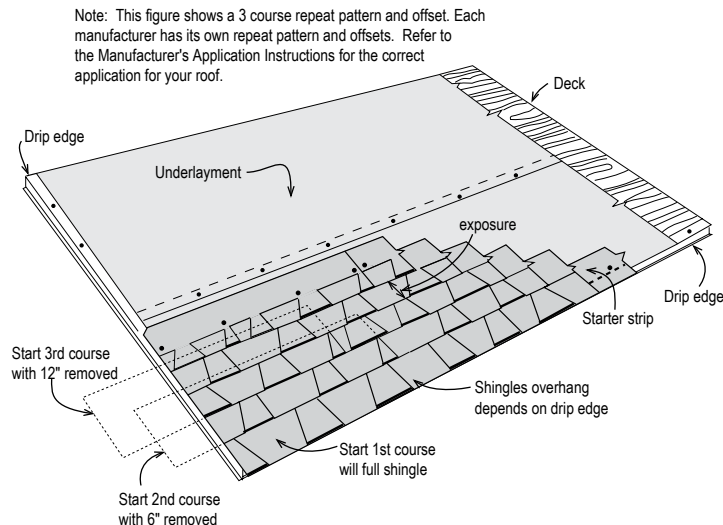

Figure 9-2
Example of a six-inch offset

For ease of illustration, the six-inch offset method is discussed and shown here in Fig. 9-2. For directions and illustration on proper application methods, consult the manufacturer's application instructions.

With the six-inch offset method, the first course begins with a full-length shingle. The second course begins with a shingle that has 6" removed from the left rake end, and the third course starts with a shingle having 12" removed. The pattern repeats itself beginning with the fourth course, where a full-length shingle is used.

VALLEYS

Several different methods of treating valleys are possible, including the open and closed cut methods, subject to the manufacturer's printed recommendations. Open valleys are preferred for heavy weight and very thick shingles, because of the difficulty in forming the shingles to the valley to make an appealing appearance with the closed cut construction. For all the methods, valley flashing should be in place before shingle application begins except for open valleys around dormers where the valley flashing must overlap the top courses of shingles along the dormer sidewalls. Thoroughly working all valley materials well into the break of the valley prior to fastening is recommended.

A. Open Valleys

Snap two chalk lines, one on each side of the valley centerline, along the full length of the valley flashing. Locate the upper ends of the chalk lines 6" apart at the ridge (i.e., 3" to either side of the valley centerline). As shown in Figure 9-3, the lower ends of the valley chalk lines should diverge from each other at a rate of $\frac{1}{8}$ " per foot of the valley length. Thus, for an 8' long valley, the chalk lines should be 7" apart at the eaves; for a 16' valley, they should be 8" apart. The minimum shingle overlap on each side of the metal valley is 6". Only sheet metal flashing is recommended for lining valleys. Other materials, including mineral-surfaced roll roofing, are not sufficiently durable to last as long as the shingles.

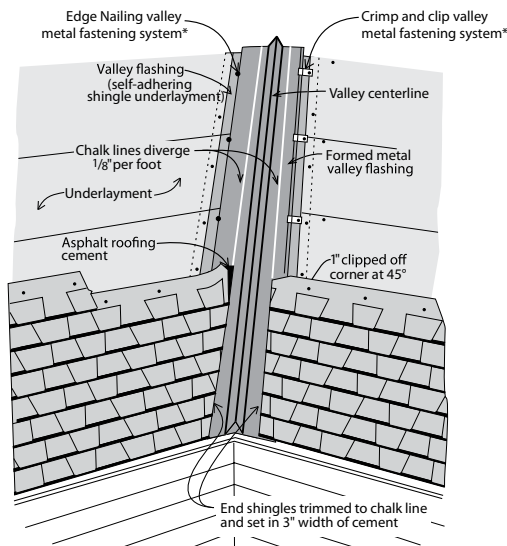

Figure 9-3
 Application of shingles in an open valley

* Two acceptable methods for valley metal fastening.

As shingles are applied toward the valley, trim the last shingle in each course to fit on the chalk line. Never use a shingle trimmed to less than 12" in length to finish a course running into a valley. If necessary, trim a section off the adjacent shingle in the course to allow a longer portion to be used. Clip 1" from the upper corner of the shingle on a 45° angle to direct water into the valley and prevent it from penetrating between the courses. Finally, to form a tight seal, cement the shingle to the valley lining with a 3" width of asphalt roofing cement (conforming to ASTM D4586/CAN/CGSB-37.5). There should be no exposed nails along the valley flashing.

B. Open Valleys for Dormer Roofs

The valley between a dormer and main roof requires special treatment. As shown in Figure 9-4, do not install the metal valley flashing until the shingle application reaches a point just above the lower end of the valley when using self-adhering shingle underlayment for the initial valley flashing.

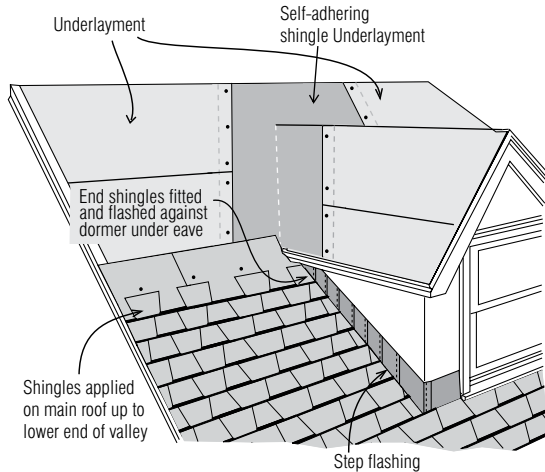

Figure 9-4
Point at which installation of open valley at dormer roof begins

As shown in Figure 9-5, apply the first or bottom layer of valley flashing (36" wide self-adhering shingle underlayment) in the same manner as any open valley flashing. Trim the lower section of the flashing so that it extends $\frac{1}{4}$ " below the edge of the dormer deck. The lower section in contact with the main roof deck should project at least 2" below the point where the two roofs meet. Extend the upper section so that the portion on the main roof extends 18" above the point where the dormer intersects the roof. Trim the portion on the dormer at the ridge.

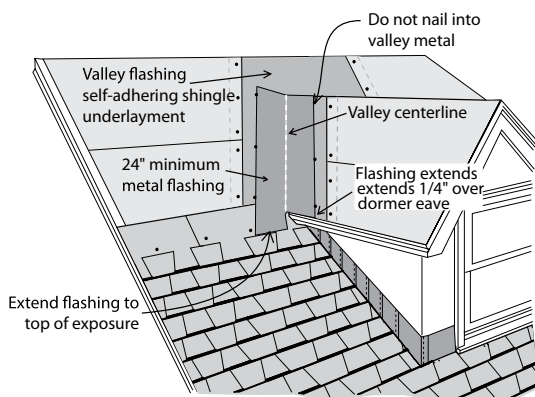

Figure 9-5
Application of flashing for an open valley at a dormer roof

Apply the valley flashing on the other side of the dormer in the same manner, extending the portion on the main roof up and over the portion from the first valley.

Trim the second or top layer of flashing (24" minimum width non-corrosive sheet metal valley flashing) on the dormer side to match the lower end of the underlying strip. Trim the side that will lie on the main deck to overlap the nearest course of shingles. This overlap is the same as the normal lap of one shingle over another for the shingles being applied. For example, for laminates it extends to the top of the shingle exposure.

Nail metal valley flashing over the bottom as in standard open valley construction. Work the flashing into the valley joint so that it lies flat and smooth in both planes up to the edge of the dormer eaves. Trim the top layer horizontally on a line with the top of the dormer ridge where it intersects the main roof.

Apply the top layer in the valley on the other side of the dormer in the same manner except at the dormer ridge where it is cemented and nailed to the first valley flashing.

Trim the lower end of the flashing on a small radius arc that bridges slightly over the point of intersection between the dormer and main roof. This shape forms a small canopy over the joint between the two decks.

Snap chalk lines on the valley flashing 3" on each side of the centerline at the top and diverging $\frac{1}{8}$ " per foot to the bottom of the valley. Resume the shingle application, trimming the end shingle in each course to the chalk lines. Clip the upper corner and embed the end shingle in a 3" wide strip of asphalt roofing cement conforming to ASTM D4586/CAN/CGSB-37.5 to seal it to the flashing. Complete the valley construction in the usual manner as shown in Figure 9-6.

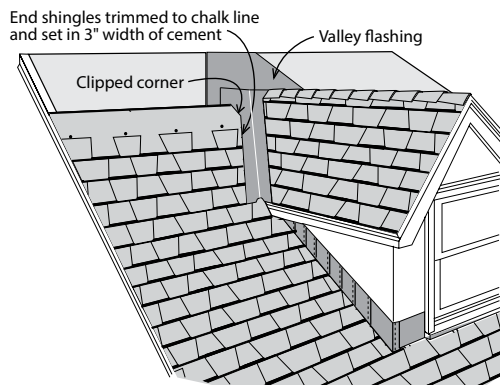

Figure 9-6
 Shingle application in an open valley at dormer roof

After shingles have been applied to both sides of the dormer roof, apply the dormer ridge shingles. Start at the front of the dormer and work toward the main roof. Apply the ridge shingles as described in Chapter 11. Apply the last ridge shingle so that it extends at least 4" onto the main roof. Slit the center of the portion attached to the main roof and nail it into place 1" inch from the upper edge. Then apply the main roof courses to cover the portion of the last ridge shingle on the main roof. Snap chalk lines so that the shingles on the main roof will continue the same alignment pattern on both sides of the dormer as shown in Figure 9-7.

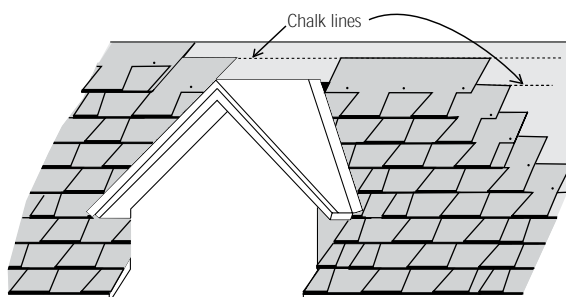

Figure 9-7
 Proper alignment of shingles above dormer using chalk lines

C. Closed Cut Valleys

[Note]

The first course and only the first course of shingles from the intersecting roof surface should be woven with the first course of shingles on the starting roof.

With valley flashing already in place, apply the first course of shingles along the eaves of one of the intersecting roof planes and across the valley. The first course and only the first course of shingles from the intersecting roof surface should be woven with the first course of shingles on the starting roof plane. For proper flow of water over the trimmed shingle, always start applying the shingles on the roof plane that has the lower slope or lesser height. Extend the end shingle at least 12" onto the adjoining roof. Do not make a joint in the valley. Neither end of the shingle should be at least 12" from the center of the valley line. If a shingle falls short, add a section in so that the joint occurs outside the line of the valley. Apply succeeding courses in the same manner, extending them across the valley and onto the adjoining roof. Press the shingles tightly into the valley. Use normal shingle fastening methods except that no fastener should be within 6" of the valley centerline and two fasteners should be placed at the end of each shingle crossing the valley.

As shown in Figure 9-8, snap a chalk line 2" from the centerline of the valley on the unshingled side. Then apply shingles on the unshingled side. Trim the shingles as they are being installed to the chalk lines and to ensure a neat installation. Trim 1" on a 45° angle from the upper corner of each end shingle upon installation. This will direct water into the valley. Finally, embed the end of each shingle in a 3" wide strip of asphalt roofing cement.

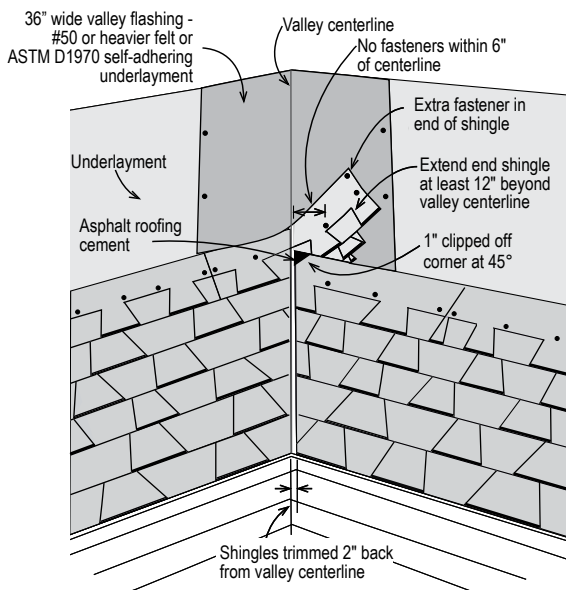

Figure 9-8
Shingle application in a closed cut valley



CHAPTER 10 FLASHING

Wherever there is an intersection of the roof plane or a penetration through the roof surface, flashing is essential for leak-free roof performance. Flashing consists of one or more thin layers of sheet metal inserted between the components of a roofing assembly and a wall or protrusion to direct the flow of water toward gutters and drains, and away from the interior of a building. While the flashing details shown in this manual indicate either strip shingles or laminated shingles, they are, in most cases, applicable to both types.

FLASHING AGAINST SIDEWALLS

Shingled roof planes that terminate against walls are best protected by sheet metal step flashing placed under the shingles as each course of shingles is applied.

Figures 10-1a and 10-1b show a method of installing step flashing at the juncture of a sidewall and a sloped roof shingled with strip shingles and laminated shingles, respectively. The metal flashing is rectangular, at least 10" long and a minimum of 2" wider than the expected exposure of the roofing shingles. For example, when used with shingles with a 5" exposure, they should be a minimum of 10" x 7". The 10" length is bent at 90 degrees to extend 5" over the roof deck and 5" up the wall assembly. Each flashing unit is placed up-roof from the exposed edge of the shingle that will overlap it so that it is not visible when the overlapping shingle is in place.

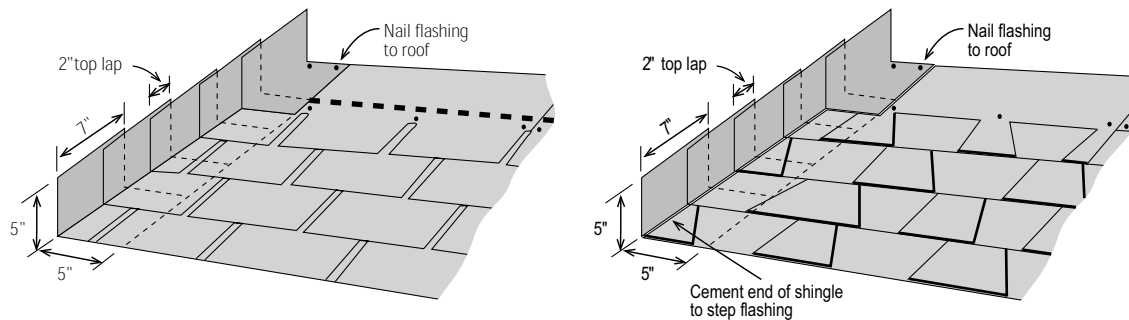

10-1a and 10-1b

Application of step flashing for 5" exposure. See manufacturer for application instructions for other exposures.

To install step flashing, place the first flashing unit over the end of the starter strip and position it so that the end shingle in the first course covers it completely. Secure the horizontal flange to the roof with two nails within 1" of the upper edge of the flashing. Do not nail the vertical flange to the wall framing as differential movement between the wall and roof will likely cause shingle buckling and or sealant breakage. Then apply the first course of shingles up to the wall. Next, position the second flashing unit over the end shingle in the first course 5" up from the butt or the same distance as the shingle exposure so that the end shingle in the second course covers it completely. Fasten the horizontal flange to the roof.

The second course of shingles follows; the end is flashed as in preceding courses and so on to the top of the wall intersection. Because the metal strip is 7" wide, when the roof shingles are laid with a 5" exposure, each flashing unit will overlap the one on the course below by 2".

Bring wall siding down over the vertical sections of the step flashing to a minimum of 2" to serve as counter flashing. Keep wood siding far enough away from the roof shingles so that it may be painted.

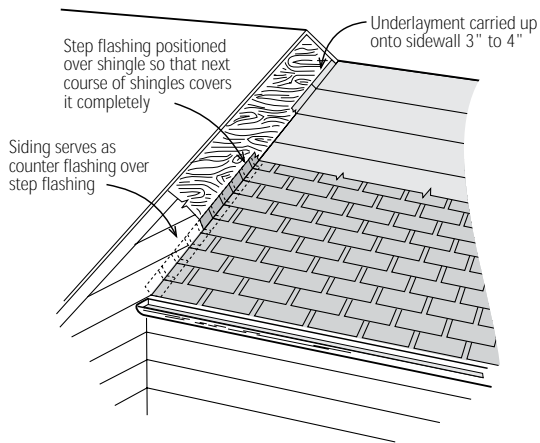

Figure 10-2
 Application of step flashing against sidewall

FLASHING AGAINST FRONT WALLS

Apply shingles up the roof until a course must be trimmed to fit at the base of the vertical wall. Plan ahead and adjust the exposure slightly in the previous two courses so that the last course is at least 8" wide. Apply a continuous piece of metal flashing over the last course of shingles by embedding it in asphalt roof cement and nailing it to the roof. The metal flashing strip should be bent to extend at least 5" up the vertical wall and at least 4" onto the last shingle course. Do not nail the strip to the wall. Apply an additional row of shingles in asphalt roof cement (conforming to ASTM D4586) over the metal flashing strip, trimmed to the width of the strip. (See Figure 10-3)

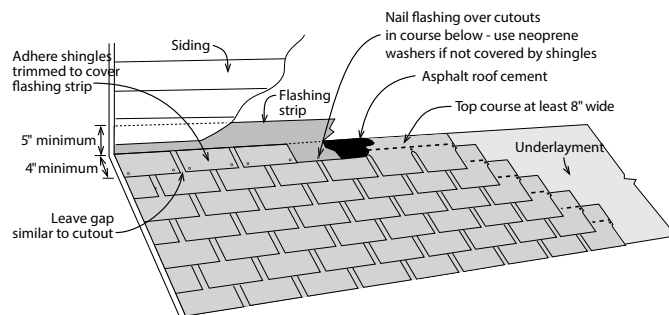

Figure 10-3
 Application of flashing against front wall

[Caution]

Excessive use of asphalt roofing cement may cause blistering.

Bring siding down a minimum of 2" over the vertical flashing to serve as counter flashing. Keep wood siding far enough away from the roof shingles so that it may be painted. Follow the siding manufacturer's recommendations for clearances. Do not nail siding into the vertical flashing.

If the vertical front wall meets a sidewall, as in dormer construction, cut flashing so that it extends at least 7" around the corner. Then continue up the sidewall with step flashing as described earlier.

SOIL STACKS AND VENT PIPES

Practically all dwellings have vent pipes or ventilators projecting through the roof that are circular in section and require special flashing methods.

Apply shingles up to the vent pipe as shown in Figure 10-4. Then cut a hole in a shingle to go over the pipe and set the shingle in asphalt roof cement conforming to ASTM D4586.

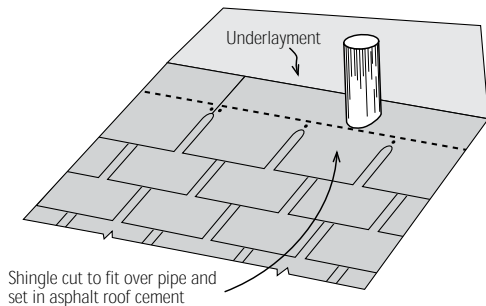

Figure 10-4
Application of shingle over vent pipe

[Caution]
Excessive use of asphalt cement may cause blistering.

A preformed flashing flange (also referred to as a "boot") that fits snugly over the pipe is then placed over the shingle and vent pipe. Place the flange over the pipe to lay flat on the roof as shown in Figures 10-5a and 10-5b. Inspections should be performed once a year to check for cracks in the flange. A variety of boot styles are available on the market, so refer to the flashing manufacturer's installation instructions.

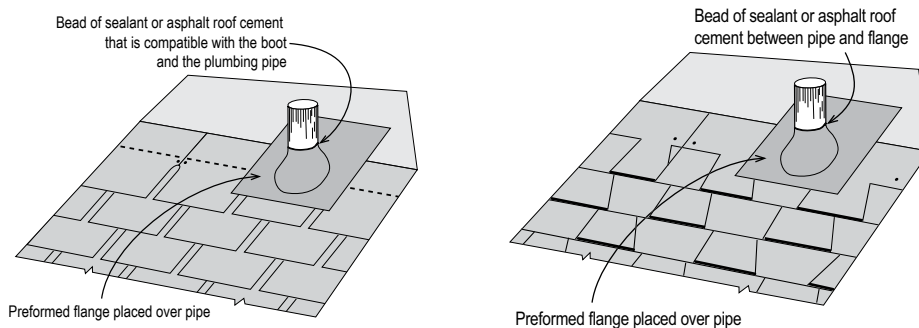

Figure 10-5a and 10-5b
Application of flashing over vent pipe

After the flashing is in place, resume shingle application. Cut shingles in successive courses to fit around the pipe and embed them in asphalt roof cement where they overlay the flange. Avoid excessive use of cement as it may cause blistering. Do not drive fastener nails any closer than 2" from the pipe. The completed installation should appear as shown in Figure 10-6a and 10-6b with the lower part of the flange overlapping the lower shingles and the side and upper shingles overlapping the flange.

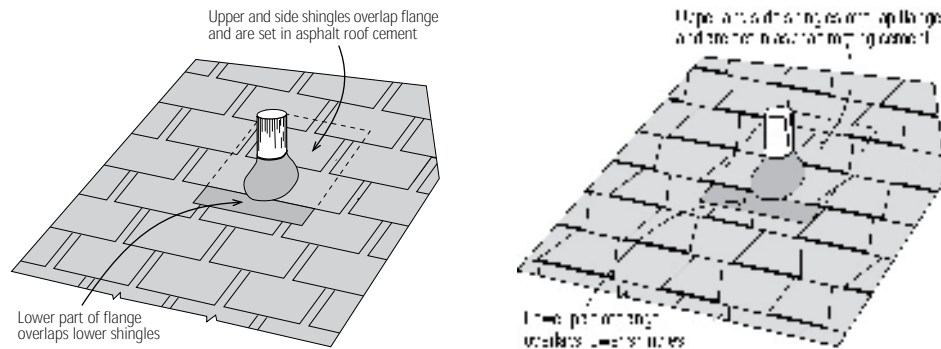

Figure 10-6a and 10-6b
 Application of shingles around flashing

FLASHING AROUND CHIMNEYS

Because of potential differential movements, flashings at the point where the chimney projects through the roof call for an arrangement of components that will allow movement without damage to the water seal. To accomplish this it is necessary to apply apron flashings that are secured to the roof deck and counter flashings that are secured to the masonry. If movement occurs, the counter flashing slides over the apron flashing without affecting water runoff.

[Note]

It is strongly recommended a cricket be installed on any chimney that is 24" or greater in width. The International Residential Code (IRC) requires a cricket or saddle be installed on any chimney greater than 30" in width.

Chimneys that project through the roof surface should have a cricket installed at the intersection of the back face of the chimney and the roof deck. The cricket (or wood saddle) is an important element in preserving the integrity of the flashing that will be installed because it prevents the buildup of ice and snow at the rear of the chimney and diverts water runoff around the chimney as shown in Figure 10-7.

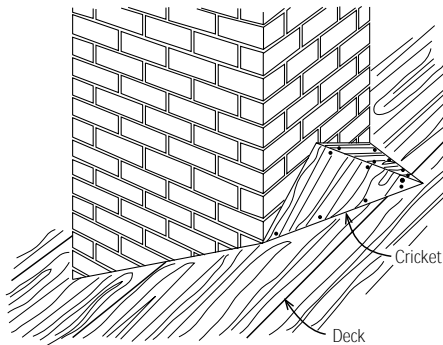

Figure 10-7
Location and configuration of chimney cricket

The cricket should be in place from the start because all roofing materials from the felt underlayment to the roofing shingles are installed over it. If it is not in place, build one as part of the deck preparation prior to applying underlayment and shingles.

Commonly, a cricket consists of two triangular sections of sheathing supported by appropriate framing members, joined to form a level ridge that extends from the centerline of the chimney back to the roof deck. Nail the sections to the deck and to each other along their meeting edge.

Apply shingles up to the front edge of the chimney before any flashings are installed. In addition, apply a coat of asphaltic masonry primer (conforming to ASTM D41) to the chimney's brickwork to seal the surface and to provide good adhesion at all points where asphalt roof cement will later be applied.

Begin the flashing construction with the installation of 0.022" (0.55 mm) (26-gauge) galvanized steel sheet or other equivalent corrosion-resistant metal apron flashing between the chimney and the roof deck on all sides.

First, apply the apron flashing to the front of the chimney as shown in Figures 10-8 and 10-9. Bend the apron flashing so that the lower section extends at least 4" over the shingles and the upper section extends at least 12" up the vertical face of the chimney. Work the flashing firmly and smoothly into the joint between the shingles and chimney. Set both the roof and chimney overlaps in asphalt roof cement placed over the shingles and on the chimney face. The flashing may be secured against the chimney with one or two nails driven into the mortar joints to hold it in place until the cement sets.

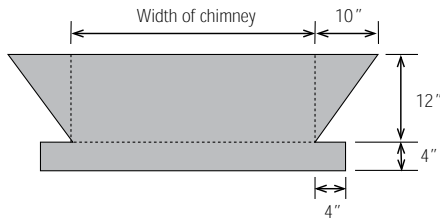

Figure 10-8
 Pattern for cutting front apron flashing

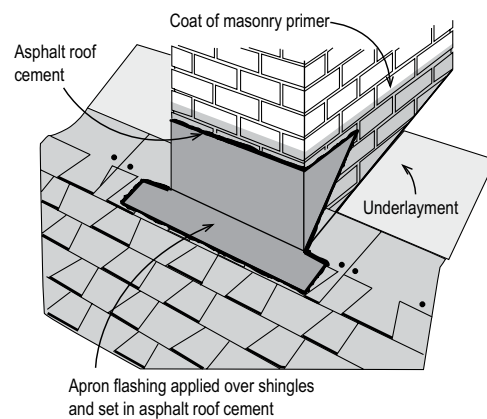
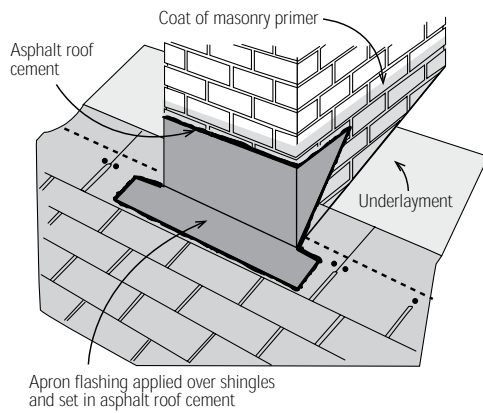

Figure 10-9a and 10-9b
 Application of apron flashing at front of chimney

Use metal step flashing for the sides of the chimney, positioning the units in the same manner as flashing a sidewall. Cut, bend and apply the step flashing as shown in Figure 10-10. Secure each flashing unit to the masonry with asphalt roof cement and to the deck with nails. Embed the end shingles in each course that overlaps the flashing in asphalt roof cement.

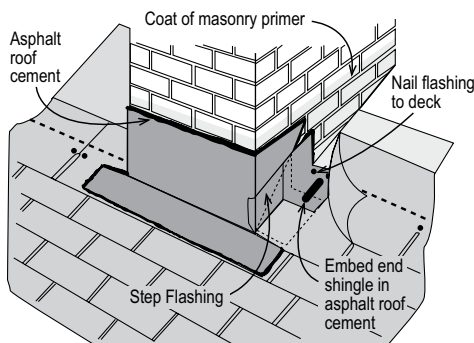

Figure 10-10
 Application of step flashing at side of chimney

Place the rear cricket metal corner flashing pieces over the base and the back of the chimney as shown in Figures 10-11 through 10-13. Cut and bend the metal corner flashing to cover the cricket and extend onto the roof surface at least 6". It should also extend at least 6" up the brickwork and far enough laterally to lap the step flashing on the sides.

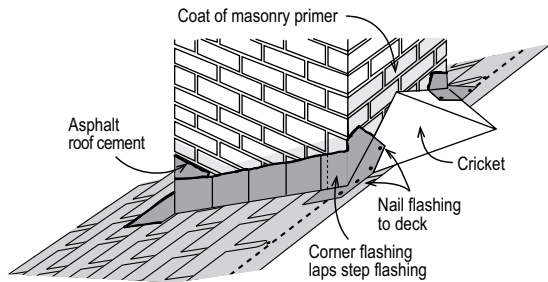

Figure 10-11
Application of metal corner flashing
at rear of chimney

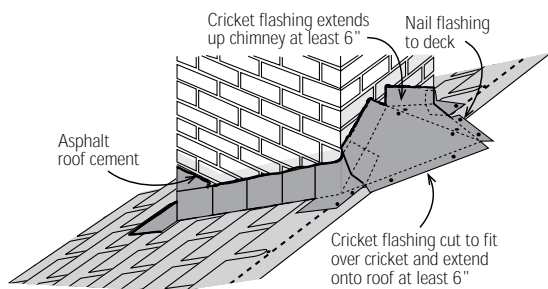

Figure 10-12
Application of cricket flashing

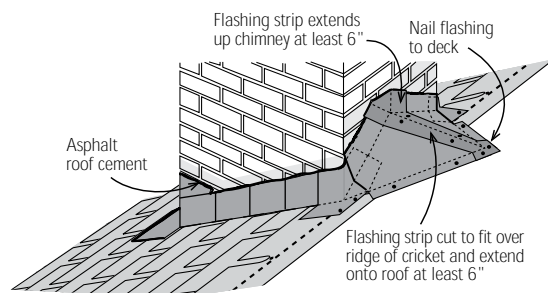

Figure 10-13
Application of flashing over ridge of cricket

If large enough, the base may be covered with shingles. Otherwise, apply the cricket flashing, bring the end shingles in each course up to the cricket and cement them in place.

Counter metal flashings must now be placed over all apron, cricket and step flashings for positive exclusion of water from the joint. Begin by setting the metal counter flashing into the brickwork as shown in Figure 10-14. This is done by raking out a mortar joint to a depth of 1½" and inserting the bent edge of the flashing into the cleared joint. Once in place and put under a slight amount of spring tension, the flashing cannot be dislodged easily. Refill the joint with Portland cement mortar. Finally, bend the flashing down to cover the flashing and to lie snugly against the masonry.

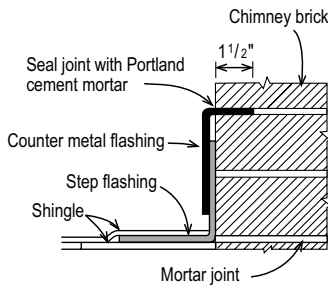

Figure 10-14
 Application of counter metal flashing

Use one continuous piece of counter metal flashing on the front of the chimney as shown in Figure 10-15. On the sides and back of the chimney, use several pieces of similarly-sized metal counter flashing pieces, trimming each to fit the particular location of brick joint and roof pitch as shown in Figures 10-16a and 10-16b.

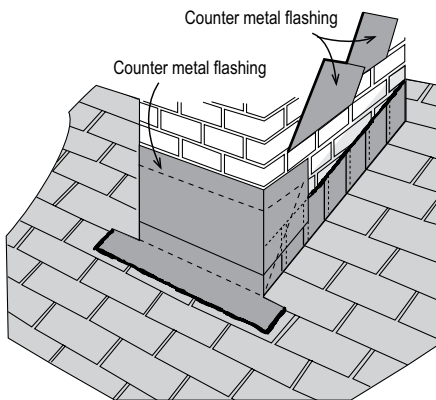

Figure 10-15
 Application of counter metal flashing at front and side of chimney

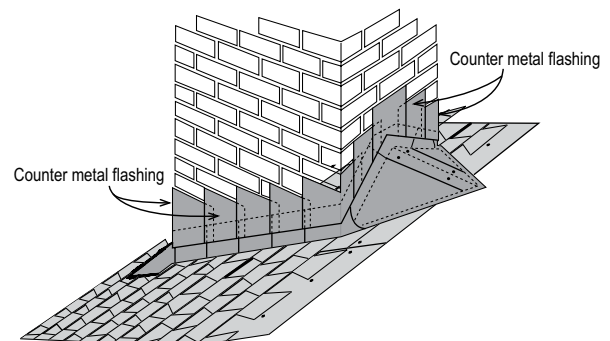
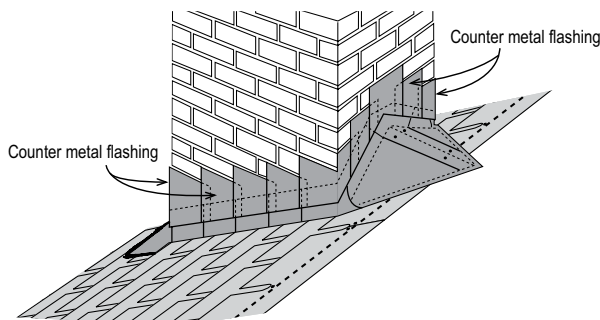

Figure 10-16a and 10-16b
 Application of counter metal flashing at side and rear of chimney

Start the side units at the lowest point and overlap each at least 3". As this is a metal cricket, it should be left unshingled in case a leak occurs (a leak would not be readily detectable if the cricket were shingled).

ROOFTOP SOLAR MOUNTS

There are many different mounting systems and types of types of solar equipment systems on the market. General guidelines for roofing practices should be followed. Some basic guidelines include the following:

Rooftop solar mounts should:

- Not be dependent on caulks and sealants to prevent water infiltration into the building.
- Have flanges incorporated such that they can be shingled into the roof system in flashing procedures so that they properly shed water and wind driven rain events.
- Be designed to withstand freeze/thaw cycling and to prevent water infiltration into the building from resulting ice dams.
- Be designed such that the solar equipment and its accessories (including wires or pipes) do not contact or rest on the surface of the roof covering.
- Be designed such that any wiring or piping will be routed over the roof edge wherever possible – avoiding any additional penetrations of the roof covering. If wiring or piping must be run through a roof penetration, it must be flashed with a flanged flashing properly shingled into the roof.

Consult manufacturers for detailed instructions and reference ARMA's Technical Bulletin, "Photovoltaic Systems and Asphalt Shingle Roofs."



CHAPTER 11 HIPS AND RIDGES

The correct application of hip and ridge cap products is an important part of a completed roof. Most shingle manufacturers market at least one hip and ridge product. While some are simple, match the shingle, and are easy to apply, others add character to the finished roof. In each case it is important to follow the manufacturer's application instructions regardless of which hip and ridge product is used. Either three-tab strip shingles or pre-cut hip and ridge shingles may be used.

The preferred hip or ridge finish shingle is a shingle made specifically for this application. Shingle manufacturers typically can provide matching hip and ridge shingles to complement the field shingles. These matching hip and ridge shingles assure continuity between the field shingles and the finished hips and ridges of the new roof. The matching hip and ridge shingles are designed to ease installation.

The following application technique is a simple hip and ridge application showing how three-tab strip shingles can be used to form a cap over many types of shingles. Care must be taken to make sure the colors match if you use a three-tab shingle for the hip and ridge that is not made by the same manufacturer of the shingle used on the roof.

First apply all field shingles, then hip shingles up to the ridge before applying the ridge cap shingle. To facilitate finishing, adjust the last few courses so that the ridge capping will cover the top courses of shingles equally on all sides of the ridge. To prevent water leaks, there should not be any of the shingle's headlap exposed and the ridge cap should provide at least 2" of overlap on each side of the hip or ridge.

Hip and ridge shingles may also be made from the three-tab shingles used to cover the roof. As three-tab shingles come in many sizes, cut the shingles down through the tab cutouts on three-tab shingles or to a minimum of 9" x 12" on two-tab, four-tab or no-cutout shingles. Taper the headlap portion of each cap shingle slightly, as shown in Figure 11-1, so that it is narrower than the exposed portion. This produces a cleaner appearance.

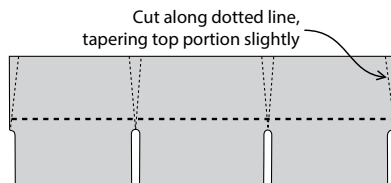

Figure 11-1
Fabrication of hip and ridge shingles
from three-tab strip shingles

[Note]

Consult the shingle manufacturer for finished dimensions of hip and ridge shingles cut from three-tab shingles.

To apply the ridge shingles, gently form each hip and ridge shingle along its centerline so that it extends an equal distance on each side of the hip or ridge. Chalk lines may assist in proper alignment. If you must apply shingles in cold weather, warm the shingle until it is pliable before forming. The shingle should form easily without cracking. Do not install shingles if cracking has occurred as a result of forming. Apply the shingles with their designed exposure without exposing the fasteners, or according to the manufacturer's instructions, beginning at the bottom of the hip or from the end of the ridge opposite the direction of the prevailing winds as shown in Figure 11-2. Secure each shingle as illustrated in Figure 11-3 with one roofing nail on each side. At the designated location from the exposed end, generally 1" more than the designed exposure and 1" up from the sides. Select nails for hip and ridge shingles so they penetrate $\frac{3}{4}$ " or completely through the decking boards.

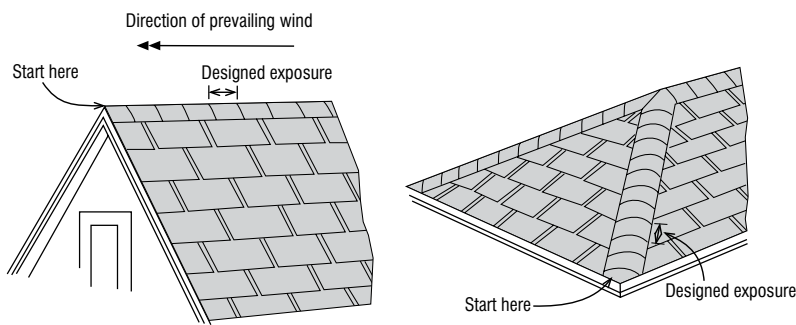

Figure 11-2
 Application of hip and
 ridge shingles

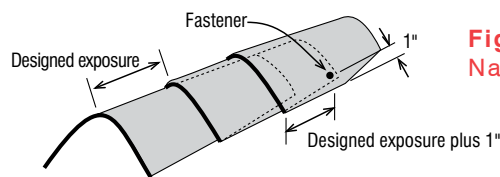

Figure 11-3
 Nail location of hip and ridge shingles

Where two hips meet the ridge as shown in Figure 11-2, face nailing of the ridge cap may be required to hold the hip and ridge shingles in place. If any of the ridge shingles are face-nailed, set the ridge shingle in asphalt roofing cement before nailing it in place. It is recommended to cover the head of the nails with a small spot of asphalt roof cement and granules.

[Note]
 If ridge vent is used, consult the vent manufacturer's application instructions.

[Note]
 In high wind areas, hip and ridge shingles that do not have sealant tabs should be hand sealed with 1" diameter spots of asphalt roof cement (ASTM D4586) under the leading edge corners of the exposed tab. Where compliance with ASTM D3161 wind resistance is required, hip and ridge shingles should be secured using a continuous bead of the manufacturer's recommended sealant applied to the underside of the leading edge and sides of the exposed tab, $\frac{3}{4}$ " to 1" in from the edges.

[Note]
 There are specialty, decorative hip and ridge laminated shingles available which may provide an added aesthetic feature to the finished roof system. Consult the shingle manufacturer regarding these types of shingles.

CHAPTER 12

APPLICATION OF SHINGLES ON LOW AND STEEP SLOPES

LOW SLOPE APPLICATIONS

Asphalt strip shingles may be used on slopes ranging from less than 4:12 down to 2:12 if special procedures are followed. Never apply shingles on slopes lower than 2" per foot (2:12).

Low slopes can lead to problems because water drains slowly from these slopes, creating a greater possibility of water backup and damage from ice dams. The special application method described below for applying shingles on low slopes will help ensure that the roof will remain weather-tight. There are two methods of applying underlayment for low slope applications. The traditional method is shown in Figure 12-1 and described in section A below. The self-adhering underlayment method is described in section B below.

A. Saturated Felt Underlayments

The "traditional" method of preparing a low-slope deck for roofing application is to cover the deck with two layers of non-perforated asphalt-saturated felt. Begin by placing and fastening a 19" wide starter strip of underlayment along the eave. Place a full width sheet over the starter sheet with the long edge placed along the eave and completely overlapping the initial layer.

All succeeding courses will be a minimum of 36" wide and should be positioned to overlap the preceding course by 19". Secure each course by using only enough fasteners to hold it in place until the shingles are applied. End laps should be 12" wide and located at least 6 feet from end laps in the preceding course.

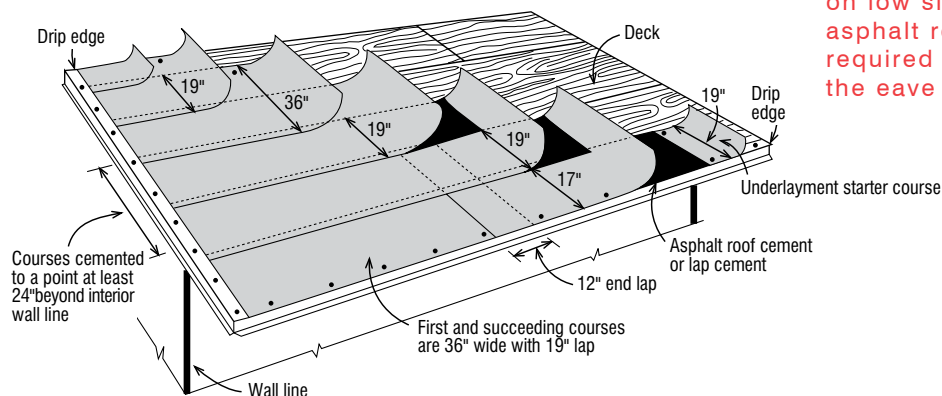

Figure 12-1
Application of underlayment on low slopes. Application of asphalt roof cement is only required where icing along the eave is anticipated.

B. Self Adhering Underlayments

Where allowed by code, if self-adhering shingle underlayment is used to cover the low slope area, it should be applied as shown in Figure 7-3. When the entire roof is covered with self-adhering shingle underlayment, adequate ventilation of the attic space is required. Applying self-adhering shingle underlayment over the entire deck creates a moisture barrier, therefore the installer must ensure that ventilation requirements prescribed by the building code are met. See ARMA's Technical Bulletin entitled "Ventilation and Moisture Control for Residential Roofing".

In roof areas where a steep slope (greater than or equal 4:12 slopes) transitions into a low slope roof area (less than 4:12 slopes), the low slope underlayment application should extend at least 24" up on the steep slope roof. The transition area between the steep slope and low slope is one that needs special attention due to water build up that can occur.

Eaves Flashing for Ice Dam Protection

The preferred method for ice-dam protection is the application of self-adhering shingle underlayment as shown in Chapter 7. Install the self-adhering underlayment beginning at the eaves edge and covering the decking to a point at least 24" up the slope beyond the warm side of the exterior wall. This may require one or more courses of the typical 36" wide self-adhering underlayment to assure proper coverage and ice dam protection. The following method is also acceptable.

Wherever there is a possibility of ice build-up or a backup of water from pine needles, leaves and other debris along the eaves, install 2 layers of underlayment cemented together or 1 layer of self-adhering underlayment from the eave to a point at least 24" beyond the interior wall line of the building (See Figure 7-3). Install waterproofing underlayment in all areas deemed to be prone to debris buildup and drainage interference - such as in valleys, around dormers, sky lights, chimneys or at changes in the deck slope junctures. Use only asphalt roofing cement conforming to ASTM D4586 or asphalt lap cement conforming to ASTM D3019, or a roof cement and application rate specified by the manufacturer. The cemented double ply underlayment serves as the ice-dam protection. (See Figure 12-1)

To construct the eaves flashing for ice-dam protection, cover the entire surface of the initial underlayment starter course with a continuous layer of asphalt roof cement applied at the rate of 2 gallons per 100 square feet; alternatively lap cement may be used at a rate of 1 gallon per 100 square feet. Consult with the individual manufacturer, as specifications may vary. Place the first full-width felt course over the starter, pressing it firmly into the cement.

After the first course is in place, coat the upper 19" with cement. Position the second course and press it into the cement. Repeat the procedure for each course that lies within the area requiring ice-dam protection. It is important to apply the cement uniformly so that the overlapping felt will float completely on the cement without touching the felt in the underlying course. Avoid excessive use of cement as it may cause blistering.

After completing the eaves flashing, secure each successive unadhered course by using only enough fasteners to hold it in place until the shingles are applied. Use care when walking on the eave flashing prior to application of shingles.

STEEP SLOPE APPLICATIONS

Steep slopes tend to reduce the adhesive effectiveness of factory-applied self-sealing adhesives especially on colder or shaded areas of the roof. Thus, special application methods may be necessary. The shingle manufacturer's application instructions for steep slope application must be followed.

The maximum slope on which shingles may be applied using normal methods is 21" per foot (or 21:12). Application of shingles on roof slopes exceeding 21" per foot (or 21:12) should follow the special method described below and illustrated in Figures 12-2 and 12-3.

Apply the shingles with fasteners recommended by the roofing manufacturer and follow the roofing manufacturer's recommendations and local building codes as to the number of fasteners required per shingle and their position. Immediately upon installation, cement each tab in place with asphalt roofing cement recommended by the shingle manufacturer. Apply the adhesive in spots equivalent to the size of a quarter. For shingles with two or more tabs, place a spot of cement under the corner of each tab (2 per tab), then press the tab into the adhesive. Be sure to cement all tabs throughout the roof. For no-cutout or most laminated shingles, place four (4) evenly spaced spots of cement under the exposed portion of the shingle.

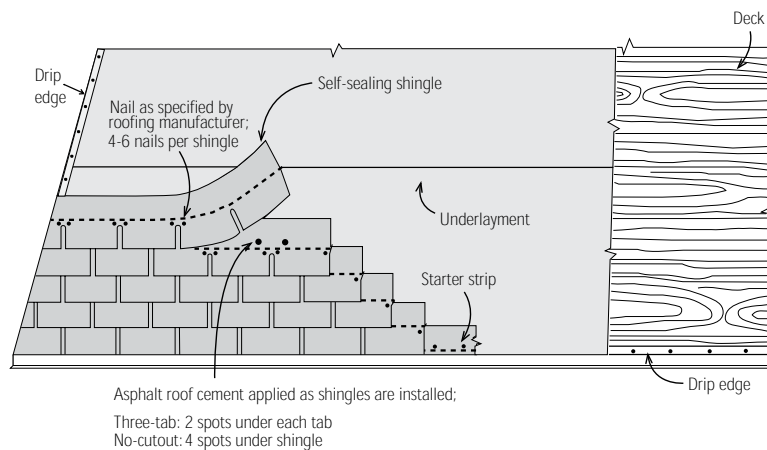

Figure 12-2
 Application of shingles
 on slopes greater than or
 equal to 21:12

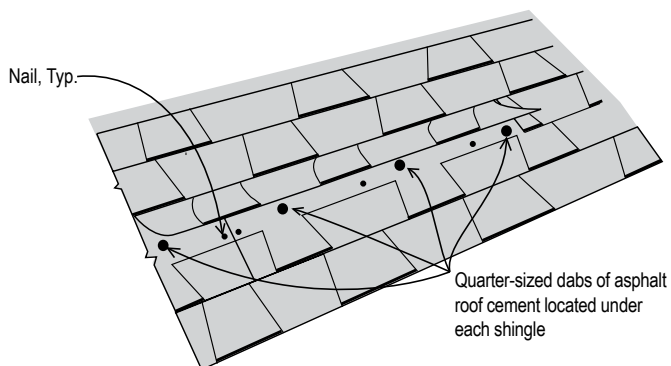

Figure 12-3
 Application of laminated
 shingles on slopes greater
 than or equal to 21:12

Application procedures for underlayments, drip edges, eave flashing (if required) and other flashings are the same as those for normal slopes.





CHAPTER 13

APPLICATION OF SHINGLES FOR REROOFING

Many of the procedures used for applying shingles on new roofs are also followed in reroofing. However, other procedures specifically designed for reroofing applications have been developed to meet the particular requirements of this type of work. The differences depend primarily on the type of material that is on the existing roof, its condition and whether the new roofing can be placed over the existing material. In all cases, the manufacturer of the shingle you choose for the new roof covering should be consulted for any special requirements in using their product as a reroof shingle.

ROOF DECK ASSESSMENT

When starting a reroofing job, the first step is to decide whether the existing roofing can or should remain in place or be removed. Complete removal may be desirable in some cases and necessary in others. In general, roofs covered with three-tab asphalt shingles or asphalt roll roofing may be left in place. Depending on local building codes, a maximum of two roofs (original and one reroof) may be installed before a tear-off becomes mandatory. Most manufacturers do not recommend installing over laminated shingles. Tile, slate, clay, cement, wood shingle, and cedar shake roof coverings must be removed down to the deck prior to installation of shingles. Any existing asphalt shingle or roll roof covering that is water-soaked or has deteriorated to the point that the existing roof or roof covering is not adequate as a base for additional roofing must be removed before the new shingle roof is applied.

The main consideration, however, is the condition of the decking and framing beneath the existing roofing because new material installed on top of old material will add weight to the structure. The roof framing must be strong enough to support these additional loads plus the weight of the roofers and their equipment and the loads associated with snow and rain.

Another equally important consideration is the shingle fastener anchorage that the existing roof deck will provide. If the roof deck has deteriorated to the point where it will not provide adequate anchorage for new roofing fasteners, or if it is not smooth or in good, structurally sound condition, it should be replaced.

Another significant factor is the condition of the surface on which the new roofing will be applied. If the old asphalt roofing shingles are curled or badly weathered to the point where providing a level surface for the new material will be difficult, they must be removed. If the surface is defective to the point where it probably will not provide adequate protection as an underlayment, if there are holes in the existing materials or if there are depressions or sagging that indicate possible structural defects, the surface must be removed and the necessary remedial work performed on the underlying deck and roof structure.

Asphalt shingle roofs that have lost most or all of their protective mineral granules may still be a satisfactory base for new asphalt shingles provided they are laying relatively flat and the remainder of the roof structure is adequate.

Regardless of whether the existing materials remain or not, inspect adjacent parts of the building for defects before starting to reroof. Repair or replace rotting or deteriorated wood trim. If necessary, refill chimney mortar joints and replace all worn flashings. Clean, rebuild, replace or reline gutters. Make sure there is adequate, code compliant, under-roof ventilation. To avoid potential condensation problems, a structure's ventilation should be carefully examined when performing any type of remodeling, not only reroofing. After correcting or repairing deficient areas, clean all debris from the roof surface.

After all repairs are made and the roof deck is properly prepared, apply the shingles following the same procedures as new construction with underlayments, drip edges, eave flashing, valley flashings and other flashings placed where necessary.

A. Old Roofing Removal

If existing roofing must be removed, completely strip the materials down to the roof deck. When preparing for roof tear-off, protect the existing structure and surrounding grounds, attic contents, plumbing vents, gutters and reference OSHA regulations. If the deck under wood shingles or shakes consists of spaced sheathing, start removing old shingles at the ridge so that broken material will not fall through the open sheathing into the attic where it will create a fire hazard and cleanup problem. Do not install plywood over spaced sheathing without providing adequate ventilation throughout the roof assembly.

Flat-surfaced shovels are convenient for removing old asphalt shingles, wood shingles, built-up roofing and felt underlayments. Be sure that all old fasteners are removed from the surface. Use a pry bar to remove soil stack and vent flashings if they are not serviceable. Be careful not to damage old metal flashings that may be used as a pattern for cutting new ones. If metal cap flashings at the chimney and other vertical masonry wall intersections have not deteriorated, bend them up out of the way so that they may be used again. Carefully remove shingles in these areas to avoid damaging reusable base flashing. For safety, keep the deck clear of waste material as the work proceeds. Sweep the deck clean after all old roofing has been removed.

If the roof deck where the old roof covering material was removed has a self-adhering shingle underlayment on portions or on all of the deck, the following is recommended:

- Self-adhering shingle underlayment is nearly impossible to remove once installed. Removing it will damage the existing decking material. Leave it on the deck unless the decking material is damaged and needs to be replaced.
- Remove, slice or nail the existing self-adhering shingle underlayment if it is not smooth and lying flat in the affected areas. Any wrinkling or uneven surface can show through new shingles.
- Apply new self-adhering shingle underlayment over the existing membrane on the roof deck. Check with the roofing manufacturer to make sure multiple layers of self-adhering shingle underlayment have no affect on the fire rating of the new shingles. Make sure the deck is smooth and flat.
- If the self-adhering shingle underlayment is only used on the eave, rake, valley and around roof penetrations then the balance of the roof should be covered with a new layer of non-perforated underlayment as covered in Chapter 7.
- Proper under-deck ventilation is especially important when self-adhering underlayment is installed over the deck.



Inspect the roof deck to determine whether it is sound. Make whatever repairs are necessary to the existing roof framing to strengthen it and to level and true the deck. Replace rotted, damaged, warped or delaminated plywood or sheathing with approved material. Cover all large cracks, knot holes, loose knots and resinous areas in the deck with sheet metal patches nailed to the sheathing. Remove loose or protruding nails or hammer them down. If the deck consists of spaced sheathing, fill in all spaces with new boards of the same thickness as the old deck or cover the entire area with decking of the type and thickness required by local codes or the shingle manufacturer.

Sweep the deck clean again and then follow the application directions described in Chapters 7, 8, 9, and 10 for new construction. Flashing details generally follow those for new construction but may differ in some respects. The last section of this chapter discusses reroofing flashing procedures.

The Northeast Recycling Council (NERC) estimates that 11 million tons of asphalt shingle scrap from tear-offs and manufacturing is produced annually in the United States. Every ton of shingles that is recycled is the equivalent of saving one barrel of oil in the form of asphalt from going to the landfill. As a result, finding a sustainable end-of-life recycling option for torn-off asphalt shingles plays an important role in providing construction professionals and consumers an alternative to land filling and for the reuse of materials. ARMA has worked to develop ways to use recycled asphalt shingles in the production / manufacturing of asphalt pavement.

Recycling waste asphalt shingles is gaining momentum and many are leveraging shingle recycling services as a growth opportunity by promoting sustainable business practices to homeowners looking for green solutions. In addition to providing an eco-friendly alternative to disposing of old shingles, recycling asphalt shingles is a cost-effective alternative to landfill disposal or other removal methods.

B. Old Roofing Remains in Place

Preparatory procedures depend on the type of existing roofing. Two situations are generally encountered:

- asphalt shingles over old asphalt strip shingles
- asphalt shingles over roll roofing

Some shingles have a greater tendency to reveal the unevenness of the surface over which they are applied. This phenomenon is known as “telegraphing,” and may influence the choice of roofing material. If you believe telegraphing may be a problem, consult individual manufacturers for advice before proceeding with installation.

Roof measurements made in any of these situations should include both rakes because it is not unusual to find a difference of several inches between rakes on the same roof. By having this information before new shingles are applied, the applicator can compensate for the difference in small increments over a series of courses.

Asphalt Shingles over Old Asphalt Shingles

Inspect the existing roof for loose, curled, lifted or broken shingles, all of which should either be removed or nailed down.

Replace all missing shingles with new shingles to provide an unbroken nailing base and to eliminate bridging in the new shingles. Buckled shingles usually indicate warped decking or protruding nails. Re-nail warped decking. Hammer down all loose or protruding nails or remove them and fasten the shingle down in a new location. Remove all badly worn drip edges and replace them with new ones. Sweep the surface clean before applying new roofing.

If existing asphalt shingles are the interlocking type, the size and shape of the shingles may result in an uneven surface. If a smoother base surface is desired, remove the old shingles and prepare the deck accordingly.

It is not recommended to install, laminated asphalt shingles directly over existing, laminated shingles due to the unevenness of the existing multi-layered shingles. The performance of the sealant feature may be compromised, preventing the shingles from sealing properly. It is acceptable to install, laminated shingles over existing three-tab strip shingles which are flat and essentially intact. Refer to page 89 for installation of standard size shingles over existing standard size shingles and for techniques to use for installing a “metric” size shingle over existing three-tab strip shingles.

Asphalt Shingles over Old Roll Roofing

After determining that the slope is suitable for the application of shingles, slit any buckles or blisters in the existing roll roofing. Press the segments flat against the deck and fasten them down to provide a smooth surface.

Remove loose or protruding nails and place new fasteners nearby. Fasten down any lap joints that have separated completely or in part. Trim old roofing that has been torn or damaged to square or rectangular sides. Inspect the underlying deck for knots or resinous areas which should be covered with sheet metal patches in the same manner as new construction. Patch the tears in the roofing with a new piece of roofing the same size as the trimmed areas and nail the patches in place. Sweep the deck clean before applying new shingles.

UNDERLAYMENT

If the old roofing has been removed, cover the roof deck with new asphalt felt underlayment in the same manner as for new construction. If the old roofing is not removed and new shingles will be applied directly over the existing material, no additional underlayment is generally required because the old roofing serves the same purpose as the underlayment.

ICE DAM PROTECTION

If reroofing over an existing roof where new ice dam protection is required (caused by the continual thawing and freezing of snow and/or the backing up of frozen slush in gutters), remove the old roofing to a point at least 24” beyond the interior wall line (Figure 7-3). Inspect the eaves, decking, and substructure and repair any damage. Follow the instructions for installation of the ice dam protection as described in Chapters 7 and 12. After the ice dam materials are applied, replace the shingles to provide an even and smooth surface prior to the application of new shingles over them, starting at the eave as described below and in Chapters 8 and 9.

STARTER AND SUCCEEDING COURSES (REROOFING)

How the shingles are applied depends on whether the existing roofing has been removed or left in place and on the type of roofing material left in place.

Direct Application Over Clean Deck or Smooth Roll Roofing: Simply follow shingle application procedures for new construction if either 1) the old roofing has been removed down to a clean deck or 2) reroofing over old, smooth or mineral-surfaced roll roofing.

Nesting and Bridging Methods of new asphalt shingles that are to be applied over existing asphalt shingles. See installation instructions below:

The **“Nesting”** procedure, described below and shown in Fig. 13-1, minimizes unevenness that might result from the new shingles “bridging” over the butts of the old shingles. The uneven appearance is more likely to occur when new single-layer and/or lighter-weight shingles are installed. The Nesting method also ensures that the new horizontal fastening pattern falls 2” below the old one. The Nesting procedure, illustrated in Figure 13-1, assumes that the new roofing has a 5” exposure and the existing roofing had been installed with a 5” exposure and proper alignment. This procedure can be followed as long as the old and new exposure dimensions are the same (See Figure 13-1). If new metal eave flashing has been added, cut the starter and first course shingles to fit such that they butt flush against the existing courses and cover the flashing to the extent required (flush or slightly overhanging).

The **“Bridging”** procedure, described below and shown in Fig. 13-2, works best when the existing shingles don't have extreme thickness variation and the new shingles have a rugged appearance sufficient to camouflage telegraphing of the uneven surface beneath it.

A. Starter Strip for “Nesting” And “Bridging” Methods

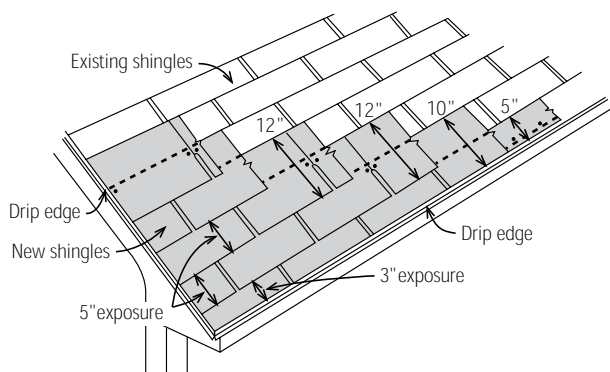

Figure 13-1
Nesting application of shingles of the same exposure. Example shown illustrates application of 5” exposure shingles over existing 5” exposure shingles.

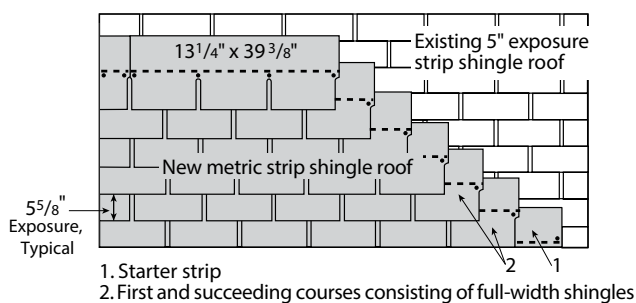

Figure 13-2
Bridging application of 5-5/8” exposure metric strip shingles over existing 5” exposure three tab shingles.

Starter strips for the “Nesting” procedure (example illustrated above in Fig. 13-1) can be made from some of the new 5" exposure shingles. Remove the 5" tabs from the lower portion and 2" or more from the upper portion so that the starter shingle height is equal in width to the exposure of the old shingles (approximately 5" in this example), thus allowing the starter shingle to "nest" flush into the existing first course shingle. In this example, the resulting starter strips will be approximately 5" wide x 36" long. Be sure the existing shingles overhang the eaves far enough to carry water into the gutter. If they do not, cut the starter strip to a width that will. Remove 4" – 6" from the rake end of the first starter strip shingle to ensure that joints between adjacent starter strip shingles will be covered when the first course is applied. Do not overlap (“bridge”) the existing course above. Apply the starter strip so that it is flush with or slightly overhanging the existing roof at the eaves with the sealant strip (if on face of shingle) exposed near the bottom edge.

Starter strips for the “Bridging” procedure (second example, illustrated in Fig. 13-2, above) can be made from some of the new “metric exposure” shingles. Example illustrated above in Fig. 13-2 is for 5-5/8" exposure metric shingles. Use a starter strip as prescribed by the manufacturer. In this example, the resulting starter strips will be approximately 7-3/4" wide x 38-3/4" – 39-3/8" long, depending on manufacturer. Be sure the existing shingles overhang the eaves far enough to carry water into the gutter. If they do not, overhang the starter strip to a width that will. Remove 4" – 6" from the rake end of the first starter strip shingle to ensure that joints between adjacent starter strip shingles will be covered when the first course is applied. Apply the starter strip so that it is flush with or slightly overhanging the existing roof at the eaves with the sealant strip (if present) exposed near the bottom edge.

B.1. First Course - “Nesting” Method

Cut 2" or more from the lower edges of the first course of shingles so that the shingles fit snugly below the butts of the existing third course shingles and align with (or slightly overhang) the lowermost/eave edge of the new starter strip. See Fig. 13-1. Begin application by placing a full-length shingle at the rake, flush with the rake edge of the starter strip. Fasten shingles in the same positions as in new construction. Do not fasten into or above the factory-applied adhesive. Fill in the remainder of the first course with full length shingles that are cut to nest below the third course shingles as described above. Check with the shingle manufacturer for specifics.

B.2. First Course - “Bridging” Method

This example illustrates the application of new 5-5/8" exposure strip shingles over existing 5" exposure strip shingles. Begin application of the first course by installing a full-size shingle flush to the rake edge of the new starter strip and flush to (or slightly overhanging) the lowermost/eave edge of the new starter strip. See Fig. 13-2. Fasten shingles in the same positions as in new construction. Do not fasten into or above the factory-applied adhesive. Fill in the remainder of the first course with full size shingles that fall below the third course shingles but bridge over the butt edge of the second course of existing shingles.

SECOND AND SUCCEEDING COURSES

For the second and succeeding courses, use full-width shingles, but at the rake, shorten the first shingle of each succeeding course by an additional 6" through the sixth course. Repeat the cycle by starting the seventh course with a full length shingle. If the alignment of the existing shingles is acceptable, simply place the top edge of the new shingles against the butt edge of the old shingles in the course above. The full-width shingles used on the second course will reduce the exposure of the first course to 3" but this area is usually concealed by gutters and the appearance should not be objectionable. For the remaining courses, the 5" exposure is automatic, coinciding with that of the existing shingles. As in new construction, apply the shingles across and then diagonally up the roof following manufacturer's instructions.

FLASHING

If the old roofing has been removed, flashing details generally follow those for new construction. However, if the existing flashings are still serviceable, they may be left in place and reused. If the old roofing is left in place, some flashing application details may differ from those for new construction. These are discussed in the following sections.

A. Valley Flashing

If the existing roof has an open valley, build up the exposed area of the valley with a code compliant roll roofing to a level flush with the existing roofing. Install new open valley flashing in the same manner as for new construction, overlapping the existing shingles. Refer to Chapter 8 for valley flashing for strip shingles and Chapter 9 for laminated shingles.

B. Flashing Against a Vertical Sidewall: Asphalt Shingles over Existing Asphalt Shingles

Continue aligning the top edge of the new shingles against the butt edge of the existing shingles. Trim the new shingles to within ¼" of the existing step flashing. Embed the last 3" of the end shingle in each course in asphalt roofing cement. Apply a bead of flashing sealant with a caulking gun at the joint between the ends of the new shingles and the sidewall.

C. Flashing Around Soil Stacks and Vent Pipes

Carefully examine the existing flashing around pipe penetrations. If they have deteriorated, remove the old flashing and install new flashings following the procedure described for soil stack and vent pipe flashing in Chapter 10.

If the existing flashing is in good condition, lift the lower part of the flange (the upper portion is held in place with nails in the upper corners) and install new shingles beneath it (a heated putty knife will help separate the cemented flange from the existing roof). Be careful not to damage or cut the metal flashing. Cover the area under the flange with asphalt roofing cement and set the flange back in place. Apply additional cement around the outside of the pipe to protect the joint between the pipe and the flange. Resume applying shingles up the roof. Cut shingles in successive courses to fit snugly around the pipe and embed them in asphalt roofing cement. Do not drive nails from applied shingle courses inside of the outer edge of the flange or close to the pipe flange as this could provide a path for water to enter if it is driven under the shingles.



D. Flashing Around Chimneys

Carefully examine the existing flashings around the chimney. If the flashings have deteriorated or if the chimney does not have a cricket, remove the affected flashings and roofing and follow the procedure described in Chapter 10 for flashing around chimneys.

If the existing flashings are in good condition, lift the lower part of the front base flashing and install new shingles beneath it. Cover the area under the flashing with asphalt roofing cement and set the flashing back in place.

At the sides of the chimney, trim the new shingles to within $\frac{1}{4}$ " of the existing step flashing. Embed the last 3" of each end shingle in a thin layer of asphalt roofing cement and apply a bead of flashing sealant with a caulking gun at the joint between the ends of the new shingles and the flashings.

If the existing cricket flashing is metal, apply new shingles up to the flashing and set the last 3" of each end shingle in cement. If the existing cricket has been shingled, treat as in the section on "Valley Flashing" discussed earlier in this chapter.

HIPS AND RIDGES

If the old roofing has been removed, apply hip and ridge shingles in the same manner as for new construction (See Chapter 11). If the existing roofing has been left in place, the old hip and ridge shingles should be removed in order to obtain a level application and better fastener anchorage. After the existing hip and ridge shingles have been removed, finish the roof at the hips and ridges in the same manner as new construction.



CHAPTER 14

APPLICATION OF NON-SELF-ADHERING SINGLE AND DOUBLE COVERAGE ROLL ROOFING

SINGLE COVERAGE

Asphalt roll roofing may be used as a primary roof covering on roof slopes down to 2" per foot using the exposed nail method and down to 1" per foot using the concealed nail method or double coverage application. Roll roofing is applied either parallel to the eaves or parallel to the rakes. It is typically manufactured in 36" wide sheets and is available in a variety of colors, weights and surfacing materials. When maximum service life is an important consideration, use the concealed nail method of application. The nail shall fit the application and have a sufficient length to penetrate 3/4" into the deck.

Store the material in a warm place on its end until ready for use, especially during the colder seasons of the year. It is not good practice to apply roll roofing when the ambient temperature is below 45°F. If rolls are handled below this temperature and have not been stored as suggested, warm them before unrolling to avoid cracking the coating. Cut the rolls into manageable 12' to 18' lengths and spread them in a stack on a smooth surface until they flatten out.

Before applying roll roofing, prepare the deck and install the necessary flashing in the same manner as described in Chapter 7 for strip shingles. Valleys will be the open type, so follow the appropriate valley flashing procedures.

[Warning]

Excessive amounts of asphalt cement may cause blistering of roll roofing. Allow sufficient time for solvents to flash off prior to joining the overlaps.

Because all roll roofing is applied with a certain amount of top and side lapping, proper sealing of the laps is critical. Use only the lap cement recommended by the roofing manufacturer. Store the cement in a warm place until ready to use. The lap cement is asphalt based and contains solvents, therefore, always take proper safety precautions. Lap cement should never be heated directly over an open flame. Do not attempt to thin the cement by diluting it with solvent.

When cementing roll roofing, apply the cement in a continuous (but not excessive) layer over the full width of the lap. Manufacturers of roofing products have application guidelines; refer to them for rate of application or thickness.

Press the lower edge of the upper course firmly into the cement until a small bead appears along the edge of the sheet. Using a roller, apply pressure uniformly over the entire cemented area. Unless otherwise noted by the roofing manufacturer, apply lap cement conforming to ASTM D3019 or ASTM D4586 /CAN/CGSB 37.4 at the rate specified by the lap cement manufacturer.

APPLICATION PARALLEL TO THE EAVES

A. Concealed Nail Method (Slopes of 1" Per Foot or Greater)

When using this method, narrow edging strips are placed along the eaves and rakes before applying the roofing. Figure 14-1 illustrates the general installation procedure, including lapping, cementing and nailing.

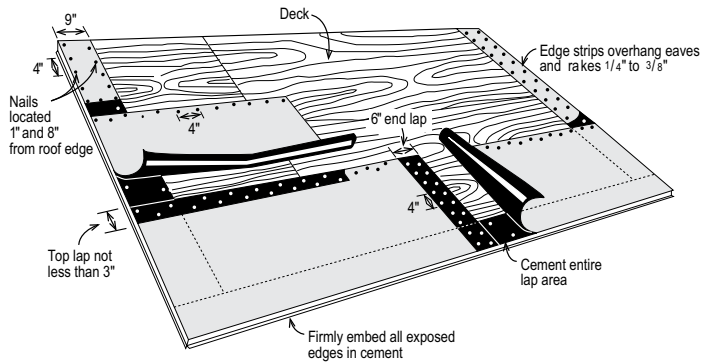

Figure 14-1
 Concealed nail method of
 applying roll roofing parallel
 to the eaves

1. Edge Strips

Place 9" wide strips of roll roofing along the eaves and rakes, positioning them to overhang the deck $\frac{1}{4}$ " to $\frac{3}{4}$ ". Fasten the strips with rows of nails located 1" and 8" from the roof edge and spaced 4" on center in each row.

2. First Course

Position a full-width strip of roll roofing so that its lower edge and ends are flush with the edge strips at the eaves and rakes. Fasten the upper edge with nails 4" on center and slightly staggered to avoid splitting the deck. Locate the nails so that the next course will overlap them a minimum of 1". Lift the lower edge of the first course and cover the edge strips with cement according to the roofing manufacturer's instructions. In cold weather, turn the course back carefully to avoid damaging the roofing material. Press the lower edge and rake ends of the first course firmly into the cement-covered edge strips. Work from one side of the sheet to the other to avoid wrinkling or bubbling.

End laps should be 6" wide and cemented over the full lap area with the recommended lap cement. Nail the underlying sheet in rows 1" and 5" from the end of the sheet with the nails spaced 4" on center and slightly staggered. End laps in succeeding courses should be offset at least 18" to prevent lining up with one another.

3. Second and Succeeding Courses

Position the second course so that it overlaps the first course at least 3" or as specified by the roofing manufacturer. Fasten the upper edge to the deck, cement the laps and finish installing the sheet in the same manner as the first course. Follow the same procedure for each successive course. Do not apply nails within 18" of the rake until cement has been applied to the edge strip and the overlying course has been pressed down.

4. Hips and Ridges

Trim, butt and nail the sheets as they meet at a hip or ridge. Next, cut 12" wide strips across the width of the sheet and bend them lengthwise to lay 6" on each side of the joint. Do not bend the strips in cold weather without first warming them. These will be used as "shingles" to cover the joint, each one overlapping the other by 6" as shown in Figure 14-2.

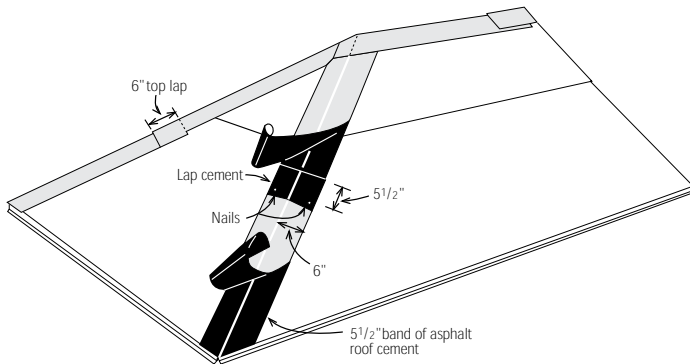

Figure 14-2
Concealed nail method of
applying roll roofing at the
hips and ridges

Start hips at the bottom and ridges at the end opposite the direction of the prevailing winds. To guide the installation, snap a chalk line 5½" from and parallel to the joint on both sides. Apply asphalt plastic cement evenly over the entire area between chalk lines from one side of the joint to the other. Fit the first folded strip over the joint and press it firmly into the cement, driving two nails 5½" from the edge of the end that will be lapped. Cover the 6" lap on this strip with lap cement. Place the next strip over it then nail and cement in the same manner as the first strip. Continue the same procedure until the hip or ridge is finished.

B. Exposed Nail Method (Slopes of 2" Per Foot or Greater)

Figure 14-3 illustrates the general installation procedures, including lapping, cementing and nailing.

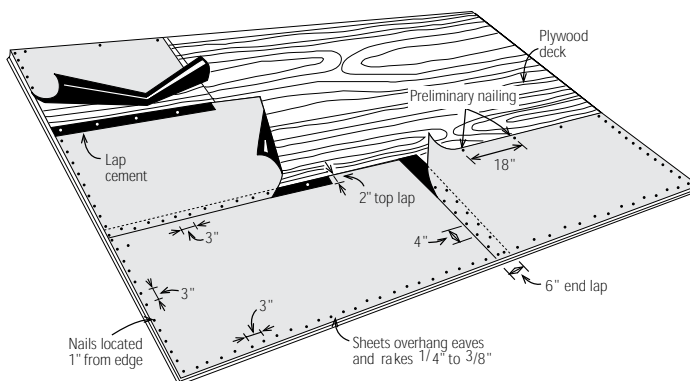

Figure 14-3
Exposed nail method of
applying roll roofing parallel
to the eaves

1. First Course

Position a full-width sheet so that its lower edge and ends overhang the eaves and rakes between $\frac{1}{4}$ " and $\frac{3}{8}$ ". Nail along a line $\frac{1}{4}$ " to $\frac{3}{4}$ " parallel to the top edge of the sheet, spacing the nails 18" to 20" apart. This top nailing holds the sheet in place until the second course is placed over it and fastened. Nail the eaves and rakes on a line 1" from and parallel to the edges of the roofing with the nails spaced 3" on center and staggered a bit along the eaves to avoid splitting the deck.

If two or more sheets must be used to continue the course, lap them 6". Apply lap cement to the underlying edge over the full lap width. Embed the overlapping sheet into it and fasten the overlap with two rows of nails 4" apart and 4" on center within each row. Stagger the rows so that the spacing is 2" between successive nails from row to row.

2. Second and Succeeding Courses

Position the second course so that it overlaps the first course by 2". Fasten the second course along the top edge following the same nailing directions as the first course. Lift the lower edge of the overlapping sheet and apply lap cement evenly over the upper 2" of the first course, then embed the overlapping sheet into it. Fasten the lap with nails spaced 3" on center and staggered slightly. Place the nails not less than $\frac{3}{4}$ " from the edge of the sheet. Nail the rake edges in the same manner as the first course. Follow the same procedure for each successive course. End laps should be 6" wide and cemented and nailed in the same manner as the first course. Stagger end laps so that an end lap in one course is never positioned over the end lap in the preceding course.

3. Hips and Ridges

Trim, butt and nail the roofing as it meets at a hip or ridge. Snap a chalk line on each side of the hip or ridge, located $5\frac{1}{2}$ " from the joint and parallel to it. Starting at the chalk lines and working toward the joint, spread a 2" wide band of asphalt lap cement on each side of the hip or ridge as shown in Figure 14-4.

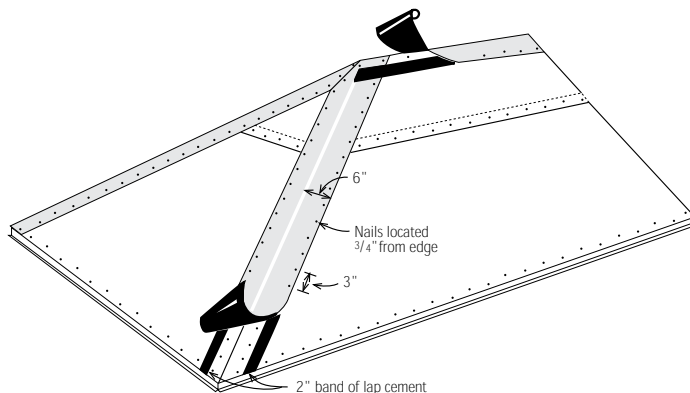

Figure 14-4
Exposed nail method of
applying roll roofing to
hips and ridges



Cut strips of roll roofing 12" wide and bend them lengthwise along the centerline so that they will lie 6" on each side of the hip or ridge. In cold weather, warm the roofing before bending it. Lay the bent strip over the joint and embed it in the cement. Fasten the strip to the deck with two rows of nails, one on each side of the hip or ridge. The rows should be located $\frac{3}{4}$ " from the edges of the strip and the nails spaced 3" on center. Be sure the nails penetrate the cemented zone underneath which will seal the nail hole with asphalt. End laps should be 6" and cemented the full lap distance. Avoid excessive use of cement as it may cause blistering.

APPLICATION OF DOUBLE COVERAGE ROLL ROOFING

Double coverage roll roofing consists of a 36" wide sheet of which 17" is intended for exposure and 19" for a selvage edge. The application method provides an additional layer of waterproofing for the roof and may be used on slopes down to 1" per foot.

The exposed portion is covered with granules while the 19" selvage portion is finished in various manners depending on the manufacturer. Some saturate the selvage portion with asphalt; some saturate and coat it.

The selvage edge and all end laps should be cemented according to the manufacturer's instructions. Thus, it is important to know the requirements of the particular product being used and to follow the roofing manufacturer's directions concerning the type and quantity of adhesive.

Make certain there is adequate roof drainage to eliminate the possibility of water standing in puddles (ponding). This is especially important on the low slopes on which double coverage roofing is commonly applied. Choose the correct type and length of nail to fit the application. The fastener should be able to penetrate the deck by $\frac{3}{4}$ " or through the deck panel.

Observe the same precautions concerning storage, application temperature and warming of the rolls as those described for single coverage roll roofing. Similarly, store asphalt cements in a warm place until ready for use.

Application of double coverage roll roofing may be parallel to the eaves or parallel to the rake. Although 19" selvage roll roofing is discussed here, any roll roofing may be applied in the same manner to obtain double coverage if the lapped portion of the sheet is 2" wider than the exposed portion.

Before applying the roofing, prepare the deck and install flashings in the same manner as described in Chapters 6, 7, and 10. Valleys will be the open type, therefore follow the appropriate valley flashing procedures.

APPLICATION PARALLEL TO THE EAVES

A. Starter Strip

Remove the 17" granule-surfaced portion from a sheet of double coverage roll roofing. Install the 19" selvage cut portion of the roofing parallel to the eaves so that it overhangs the drip edge $\frac{1}{4}$ " to $\frac{3}{8}$ " at both the eaves and rakes. Fasten it to the deck with two rows of nails, one on a line 5" from the top edge of the strip, the other on a line 1" above the lower edge. Nail spacing should be 12" on center, slightly staggered in each row as shown in Figure 14-5.

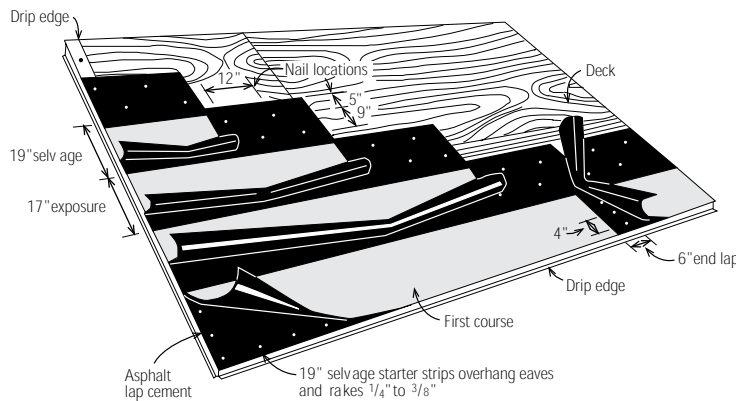

Figure 14-5
 Application of double
 coverage roll roofing
 parallel to the eaves

B. First Course

Cover the entire starter strip with asphalt roof cement. Avoid excessive use of cement as it may cause blistering. Then position a full-width sheet over it. Place the sheet so that the side and lower edge of the granule-surfaced portion are flush with the rake and eave edges of the starter strip. Fasten it to the deck with two rows of nails in the selvage portion. Locate the first row 5" below the upper edge and the second row 9" below the first with the nails spaced 12" on center and staggered.

C. Succeeding Courses

Position each succeeding course so that it overlaps the full 19" selvage width of the course below and nail the selvage portion in the same manner as the first course. Carefully turn the granule portion of the sheet up and apply cement to the full selvage portion of the underlying sheet. Spread the cement to within ¼" of the edge of the exposed portion. Press the overlying sheet firmly into the cement. Apply pressure over the entire lap using a broom or light roller to ensure complete adhesion between the sheets. It is important to apply the cement so that it flows to the edge of the overlying sheet under the application pressure. Avoid excessive use of cement as it may cause blistering. Follow the roofing manufacturer's instructions.

[Caution]

To prevent the sheets from splitting, never cement roll roofing directly to the deck. To make certain that roll roofing is not cemented to the deck when hot application is allowed, nail down a base sheet.

D. End Laps

All end laps should be 6" wide. Fasten the underlying granule-surfaced portion of the lap to the deck with a row of nails 1" from the edge. Space the nails 4" on center then spread asphalt roof cement evenly over the lap area. Embed the overlying sheet in the cement and secure the selvage portion of the sheet to the deck with nails on 4" centers in a line 1" from the edge of the lap. Stagger all end laps so that those in successive courses do not line up with one another.

HIPS AND RIDGES

Trim, butt and nail the roofing sheets as they meet at a hip or ridge. Snap chalk lines 5½" from and parallel to the joint on each side to guide the installation.

Next, cut 12" x 36" strips of roll roofing that include the selvage portion. Bend the strips lengthwise to lie 6" on either side of the joint. In cold weather, be sure to warm the strips before bending. Start applying the strips at the lower end of the hip or at the end of the ridge opposite the direction of prevailing winds.

Cut the selvage portion from one strip to use as a starter. Fasten this strip in place by driving nails 1" from each edge and 4" on center over the full length. Cover it completely with asphalt roof cement. Fit the next folded strip over the starter and press it firmly into the cement, nailing it in the same manner as the starter but only in the selvage portion. Continue the process until the hip or ridge is completed. Figure 14-6 illustrates the procedure.

Figure 14-6
Application of double coverage
roll roofing to hips and ridges

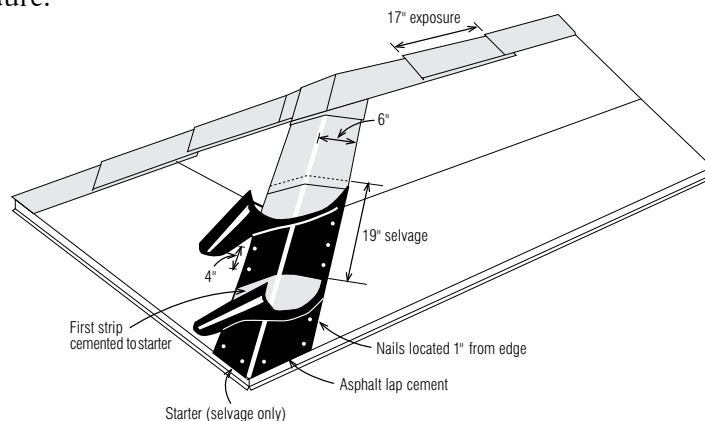



Double coverage roll roofing is frequently used on sheds which contain no hips or ridges. To finish this type of roof, trim and nail the selvage portion of the last course to the edge of the roof. Then trim the exposed, granule-surfaced portion that had been cut from the starter strip to fit over the final selvage portion and cement it in place. Finally, overlay the entire edge with metal flashing and cement it in place.

[Note]

Refer back to Chapter 3 on attic ventilation.



CHAPTER 15

APPLICATION OF SELF-ADHERING ROLL ROOFING

Self-adhering roll roofing for use on residential structures is manufactured in 36" or 39^{3/8}" (1 meter) wide sheets and is used in single, double or triple ply systems depending on the local building code requirements. They are available in a variety of weights, surface materials and colors. These products may be applied on roof slopes from 1/2" to 6" per foot on solid smooth deck surfaces. There can be three components used in these systems:

- **Base sheet** is a non-self adhering product that is mechanically attached to the deck and is always the first ply in the roof covering system. This product is only used on nailable deck substrates which include wood plank, ply-wood and OSB and cementitious wood-fiber panel decks.
- **Mid-ply or base-ply** is a self-adhering layer of the system that may be used directly on the deck surface or as an intermediate ply on top of the base sheet in applications with one, two or three layers.
- **Cap sheet** is a self-adhering membrane that is mineral surfaced and is used as the top layer of the system as it has the weathering surface. The mineral surfacing provides the roof color and can be selected to match or as a complimentary color to steep slope shingles.

Due to individual product variations, it's important to comply with the manufacturer's installation instructions. Use components from one manufacturer for multi-layer applications to ensure all materials in the system are compatible. Mixing manufacturers' materials, such as using one manufacturer's base sheet with another manufacturer's cap sheet, is not recommended.

GENERAL APPLICATION

- The decking material must be smooth, clean and dry, free of dust, debris, oil, sharp projections and other foreign materials, before application.
- Do not leave the bare deck exposed to the environment for extended periods as dust, salt spray, pollen and other contaminants may limit the adhesion ability.
- The minimum thickness of wood deck is a 15/32" code compliant decking plywood or 7/16" code compliant decking OSB as required by local building codes.
- When reroofing, infill holes in decking with like materials or cover with minimum 32 gauge galvanized sheet metal, nailed in place.
- Ensure the deck has positive drainage. Refer to the local building code for slope and drainage requirements.
- Ambient temperatures must be a minimum of 40° F and rising throughout the application. Consult the manufacturer for instructions. Do not apply roofing when ice, snow, dew or rain is present.
- Drip edges are required on all rake and eave edges.

- Follow the manufacturer's instructions.
- The use of chalk lines to keep the roll application straight is recommended.
- Make sure the self-adhering membranes are fully adhered and do not have wrinkles, voids or bubbles.
- Adequate under-deck ventilation is required with any of these application systems. Refer to Chapter 3 for proper ventilation practices.
- Self-adhering membranes may be cut to lengths that are easily handled.
- When primer is used, it must be applied at the manufacturer's recommended rate and be allowed to dry thoroughly before applying any roofing plies.
- Before applying roofing plies, refer to the manufacturer's installation instructions and construction details for application, location and configuration of flashing materials.

[Note]

The following descriptions of single, double and triple layer systems provide basic information. The details on how to correctly install these systems are provided by the system manufacturer.

SINGLE LAYER APPLICATION

The self-adhering cap sheet is applied directly to the deck, covering all flashing and drip edges, on minimum 1" per foot slopes (1:12). The deck and any metal flashing and drip edges must be primed with a primer recommended by the cap sheet manufacturer. The cap sheet manufacturer may require the lap area of each course to be back nailed and all the seams to be rolled with a heavy steel or silicone roller.

DOUBLE LAYER APPLICATION

This system consists of a cap sheet layer applied over either a base sheet or base-ply sheet as the bottom layer. This system may be installed on solid wood decks having a minimum slope of ½" per foot (½:12). If the base sheet is used it must be mechanically fastened to a nailable wood deck. If the self-adhering mid-ply or base-ply sheet is used it can be installed on nailable as well as non-nailable decks. Flashing details are complex and the manufacturer's application instructions must be followed. When applying the cap sheet over the mid-ply or base-ply sheet, any metal or wood areas to which the cap sheet is being applied to must be primed.

TRIPLE LAYER APPLICATION

This system offers the most redundancy of the three applications and consists of a base sheet and a mid-ply sheet as the first two layers of this system and a cap sheet for the top layer. This system may be used on any solid wood deck surface down to ½" per foot slopes (½:12). This system is the most durable and longest lasting of the three application methods. The base sheet must be mechanically fastened to a nailable wood deck. The mid-ply or base-ply sheet is fully adhered to the base sheet. If the mid-ply or base-ply sheet is to be adhered to any wood or metal surfaces, they must first be primed. Flashing details are more complex and the manufacturer's application instructions must be followed. When applying the cap sheet over the mid-ply or base-ply sheet, any metal or wood areas that the cap sheet is being applied must be primed.



CHAPTER 16

INSPECTION OF THE COMPLETED JOB

INSPECTION

The application of asphalt shingle roof systems is not an exact science. It is a craft involving skilled professionals who work at elevated heights and changing weather conditions using a broad range of materials, designs, practices and techniques. The quality of application workmanship is best measured using application criteria and inspection procedures that take into account not only roof system performance but also reasonable variances that are encountered with field application.

A quality roofing installation is dependent upon the applicators' craftsmanship during application. Confirming installation quality while the work is in progress offers the applicator a number of opportunities to make certain that the materials are appropriate for the application, properly placed, properly fastened and in good condition.

If in-process inspections have been effective, the primary objective of a final inspection is to close out the job. Upon final inspection, give the roof one last cleaning. Remove any loose shingles, cuttings, nails, wood shavings, boards and other debris that remains on the roof. Remove any debris from valleys, gutters and downspouts to ensure that they are unobstructed and will carry water away from the building quickly and efficiently.

Damaged shingles cause leaks and detract from the appearance of the finished job. Thus, you must be sure to inspect the finished roof for any broken, torn or damaged shingles. Remove damaged shingles by drawing the fasteners from the damaged shingle and the one immediately above it. Carefully fit a new shingle into place, fasten and hand seal both shingles.

Inspect all areas on which asphalt cements have been used to ensure that the materials have adhered properly and there are no bubbles in the roofing. If re-cementing is required to obtain a good bond, carefully lift the overlying material to avoid damaging it, apply the cement and work it thoroughly into the material. Replace the overlying layer, pressing it firmly into the cement.

Regardless of the type of asphalt roofing material used, check for proper fastening. Fasteners should not be exposed unless the installation procedures specifically call for exposure. No fasteners should protrude from or be driven into the surface of the roofing material. Protruding fasteners must be driven properly or replaced. Remove any bent or incorrectly placed fasteners as well as any that are driven too far into the surface of the asphalt roofing. Pack the hole with asphalt roofing cement and drive a new fastener nearby.

Before leaving the roof, examine the entire roof area for overall appearance and any defects that might have been overlooked at closer range including:

- Chimney flashings
- Hip and ridge shingles
- Proper ventilation
- Vent pipe or side wall flashings
- Overhangs
- Shingle distortion
- Scuff marks
- Valley construction

Remove scaffolding and ladders carefully to avoid scraping the siding, breaking windows, breaking tree branches or damaging shrubbery. Thoroughly clean the site of roofing materials, cuttings, scraps, wood and any other debris remaining from the roofing work. If possible, before leaving the job, have the owner make a final inspection of the grounds and obtain his approval of the work.

COLOR SHADING

As the roof is viewed from different angles or under different light conditions, certain areas sometimes appear darker or lighter. This difference in appearance is commonly called shading and most commonly occurs on single layer shingles like three-tabs or non-cutout shingles. The frequency of shading on most multi-layer laminated shingles is low, but still possible.

Shading is a visual phenomenon that in no way affects the performance of the shingles. It's usually a result from slight variations in texture that occurs during shingle production. The variation necessary to cause shading with black or other dark colors is so slight that it cannot be detected during the manufacturing process.

When light is reflected from these roofs the appearance will vary as the viewer walks past the building. The impact will depend on the position of the sun and the overall light intensity. When the sun is directly overhead, the shading may disappear.

Shading is most frequently observed in the case of black or dark color shingles. Since only a small part of the light is reflected from a dark roof, very slight differences in texture of the shingles may cause this problem.

In the case of white and light-colored shingles, the total amount of light reflected is considerably greater and observable differences are diminished.

Blends made of a variety of colors are designed to camouflage this effect and observable differences are further reduced. Lighter-colored blends reduce this effect more than darker blends. Over time, weathering will reduce the noticeable effects of shading.

The appearance of shading can also be caused by:

Backing Material

The backing material used to keep the shingles from sticking together in the bundle can rub off or transfer to the surfacing material. Natural weathering from rains and sunlight should eventually remove this loose backing.

Storage

Shingles that have been stacked too high or have been stored over long periods of time can develop minor staining from the lighter oils contained in the asphalt coating. Natural weathering will usually eliminate this.

Application

Manufacturers recommend that shingles be applied by starting at the bottom of the roof, working across and up. This will blend shingles from one bundle into the next and minimize any shade variation from one bundle to the next.

- Slight shading should be accepted as a normal variation in asphalt roofing.
- Allow sufficient time to wash off loose backing material and to permit any oil stains to weather out.
- Install shingle blends having variations in color to help minimize shading possibilities.
- Insist upon manufacturer's recommended application methods to minimize shading.

Shading is an optical effect and in no way influences the durability of asphalt roofing materials. Slight shading is normal and unavoidable.



CHAPTER 17

ROOF CARE AND MAINTENANCE

ROOF CARE

Properly installed asphalt roofing products will provide years of protection. Even so, there are certain aspects of roof care that the owner should be aware of to ensure maximum roof performance. Safety must be the first priority when working on a roof. Observe every precaution, safety guidelines, and safe work practices, or have a roofing professional do the work.

Limit walking on roofs to a minimum to avoid damaging the roof surface. When workmen have to climb onto the roof to service or install a chimney, solar collector, television antenna or other roof element, require them to use care to protect the roofing.

Never allow water from a downspout to discharge directly onto a roof below. Connect an upper story downspout to a lower level gutter with drains installed on the lower roof.

Make annual inspections of the roof to evaluate its general condition and detect any potential leakage problems before they develop. The best time for an inspection is the spring after severe winter weather conditions (and the damage they may have inflicted) have passed. In addition, the spring season is ideal for repairs if they are necessary. Make the inspections from the ground or through upstairs windows where the roof surface can be observed. Binoculars are a good tool to use for the inspection. Never paint or coat asphalt roofing materials to change the color or give the roof a “new” look. The use of paint or coatings may void the manufacturer’s warranty. Consult the individual manufacturer.

Inspect the underside of the roof deck from the attic to detect leaks. Carefully examine areas where penetrations or structural intersections occur to detect evidence of leakage such as wet, water-stained roof decking or attic flooring. Penetrations and intersections are typically the most vulnerable to water infiltration and must be flashed properly to prevent leaks. Remember that in cooler climates, water stains may be due to condensation as a result of inadequate attic ventilation.

Where problems are identified, call in a competent roofer to make an on-roof inspection and to perform any repairs that are necessary.

Keep trees trimmed to prevent branches from scuffing the roof surface. This will also keep the roof surface dryer helping to inhibit growths such as algae, mold, or lichen. Keep climbing plants trimmed back from the roof.

Keep gutters, downspouts and roof surfaces clear of fallen leaves, pine needles, twigs and other debris so that water will drain freely.

Whenever a new element is added to the roof, such as solar panels, make certain proper flashing procedures are followed to maintain the integrity of the roofing. Be sure anchors are made of a non-corrosive material to eliminate the possibility of metal discoloration or “iron stains” on the roof.

When removing snow or ice from a valley or other roof areas, proper care must be taken to avoid damaging the roof. For safety, use a soft broom on a long extension pole. Never climb onto a wet or snow-covered roof.

KEEPING THE ROOF CLEAN

Algae Discoloration and Moss Growth

A type of roof discoloration caused by algae and commonly misidentified as “fungus growth” is a frequent aesthetic concern throughout the country. It is often mistaken for soot, dirt, moss or tree droppings. The primary species of algae observed is a Cyanobacteria which is identified as a Gloeocapsa organism. This type of roof staining organism is contained in and transported through the air, and tends to collect and grow upon roofing structures. Natural pigments produced by this organism may cause white or colored roof areas to gradually turn dark brown or black. It should be noted that almost all types of roofing systems are susceptible to algae discoloration. It is most visible on white and light colored roofs, but it also will discolor darker roofs where it is less noticeable. This algae is well adapted to survive in harsh conditions such as heat, UV, cold, heavy rains and dry spells, but while it can affect the roof's appearance, it has not been shown to affect the service life of the roofing.

Moss growth damages asphalt shingles. Moss growth may also cause problems for a roof system by blocking the intended water shedding process of a shingle roof and by holding debris on a roof.

Control and Cleaning

Algae, moss and lichen need moisture to grow. To reduce the time moisture is available on the roof, do not allow the accumulation of roof debris, such as leaves or pine needles. Debris should be removed in a safe manner by a leaf blower or similar, non-abrasive method. The air flow must be directed down the slope to avoid driving debris under the edges of the shingles. Never allow water from a downspout to pour directly onto a roof below. Connect an upper story downspout to a lower level gutter with drains installed on the lower roof. Keep the gutters clear to promote proper water drainage. It is also helpful to keep tree limbs pruned back from the roof to reduce shaded areas and allow free air flow.

Algae, moss and lichen are difficult to remove from roofing surfaces. They are generally controlled with a diluted cleaning solution (Contact the roofing manufacturer for details). Spray the solution with a pump-type garden sprayer on the roofing; do not scrub as doing so will loosen and remove granules. Apply the solution carefully to avoid damaging other parts of the building and/or the surrounding landscape. If possible, work from a ladder or walk boards to avoid walking directly on the roof surface as it may become very slippery. Observe safety precautions whenever working on or near the roof. After applying the cleaning solution, let it set for a time period and then rinse the solution off the roof with water from a hose using low pressure.

[Caution]

This cleaning process will make the roof slippery and potentially hazardous during the treatment. Always use fall prevention equipment and rely on professionals to clean the shingles for safety's sake.

DO NOT use a power washer or any type of brush or broom to clean algae from the roof surface. Do not walk on a roof that has algae stains regardless if it is dry. The algae make a roof surface very slick which is intensified when it is wet with water or the cleaning solution. Your shingle manufacturer may be able to recommend companies specializing in roof cleaning to clean your roof. The effectiveness of such cleaning is only temporary and the discoloration may recur. However, several types of algae resistant roofing have been developed and are now commercially available. These asphalt roofing products are specifically designed to inhibit most algae growth for extended periods of time and can be quite effective.

There are commercially available algae and moss control chemicals. Contact the manufacturer of the shingles before using any of these chemicals. Some of these chemicals may contribute to rapid roof system failures.

Refer to the ARMA Technical Bulletin, "Algae Discoloration of Roofs."

GLOSSARY

Algae Discoloration: A type of roof discoloration caused by algae. Commonly described incorrectly as fungus growth.

ASTM International: A voluntary organization concerned with development of consensus standards, testing procedures and specifications.

Asphalt: A bituminous waterproofing agent applied to roofing materials during manufacture.

Asphalt Primer: A thin liquid bitumen applied to a surface to improve the adhesion of self-adhering membranes and to absorb dust.

Asphalt Roof Cement: An asphalt-based cement used to bond roofing materials. Also known as flashing cement or mastic; should conform to ASTM D4586 (Asbestos Free).

Back Surfacing: Fine mineral matter applied to the back side of shingles to keep them from sticking together.

Base Flashing: That portion of the flashing attached to or resting on the deck to direct the flow of water onto the roof covering.

Base-ply sheet: A product intended to be the base or middle ply in a residential self-adhering roll roofing installation.

Base Sheet: A product intended to be used as a base ply in a self-adhering roll roofing installation.

Blisters: Bubbles that may appear on the surface of asphalt roofing after installation.

Brands: Airborne burning embers released from a fire.

Bridging: A method of reroofing with metric-size shingles.

Built-Up Roof: A flat or low-sloped roof consisting of multiple layers of asphalt and ply sheets.

Bundle: A package of shingles. There are typically 3, 4 or 5 bundles per square.

Butt edge: The lower edge of the shingle tabs. (See Figure A.)

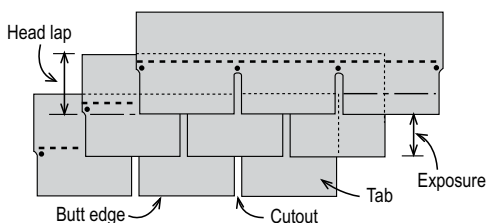

Figure A

Cap Sheet: A mineral surfaced material that is used by itself or as the top layer of multi-ply roof covering systems.

Caulk: To fill a joint with mastic or asphalt cement to prevent leaks.

Cement: See Asphalt Roof Cement.

- Chalk Line:** A line made on the roof by snapping a taut string or cord dusted with chalk. Used for alignment purposes.
- Class “A”:** The highest fire test classification for roofing as per ASTM E108 or UL790. Indicates roofing is able to withstand severe exposure to fire originating from sources outside the building.
- Class “B”:** Fire test classification that indicates roofing material is able to withstand moderate exposure to fire originating from sources outside the building.
- Class “C”:** Fire test classification that indicates roofing material is able to withstand light exposure to fire originating from sources outside the building.
- Closed Cut Valley:** A method of valley treatment in which shingles from one side of the valley extend across the valley while shingles from the other side are trimmed 2" from the valley centerline. The valley flashing is not exposed.
- Coating:** A layer of viscous asphalt applied to the base material into which granules or other surfacing is embedded.
- Collar:** Pre-formed flange placed over a vent pipe to seal the roof around the vent pipe opening. Also called a vent sleeve.
- Concealed Nail Method:** Application of roll roofing in which all nails are driven into the underlying course of roofing and covered by a cemented, overlapping course. Nails are not exposed to the weather.
- Condensation:** The change of water from vapor to liquid when warm, moisture-laden air comes in contact with a cold surface.
- Counter Flashing:** That portion of the flashing attached to a vertical surface to prevent water from migrating behind the base flashing.
- Course:** A row of shingles or roll roofing running the length of the roof.
- Coverage:** The number of layers of material between the exposed surface of the roofing and the deck; i.e., single coverage, double coverage, etc.
- Cricket:** A peaked saddle construction at the back of a chimney to prevent accumulation of snow and ice and to deflect water around the chimney.
- Cutout:** The open portions of a strip shingle between the tabs. (See Figure A.)
- Deck:** The surface, installed over the supporting framing members, to which the roofing is applied. The minimum thickness of a wood deck is a 15/32" exterior grade plywood or 7/16" exterior grade OSB or as required by local building codes.
- Dormer:** A framed window unit projecting through the sloping plane of a roof. (See Figure B.)

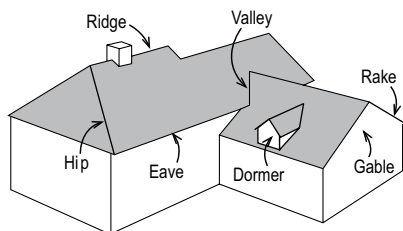
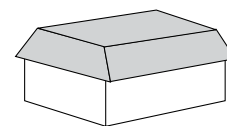

Figure B



Mansard Roof

Double Coverage: Application of asphalt roofing such that the lapped portion is at least 2" wider than the exposed portion, resulting in two layers of roofing material over the deck.

Downspout: A pipe for draining water from roof gutters. Also called a leader.

Drip Edge: A corrosion-resistant, non-staining material used along the eaves and rakes to allow water run-off to drip clear of underlying construction.

Eave: The horizontal, lower edge of a sloped roof. (See Figure B.)

Eave Flashing: Additional layer of roofing material applied at the eaves to help prevent damage from water back-up.

Exposed Nail Method: Application of roll roofing in which all nails are driven into the cemented, overlapping course of roofing. Nails are exposed to the weather.

Exposure: That portion of the roofing exposed to the weather after installation. (See Figure A.)

Felt: Fibrous material saturated with asphalt and used as an underlayment or sheathing paper.

Fiberglass Mat: An asphalt roofing base material manufactured from glass fibers.

Flashing: Pieces of metal used to prevent seepage of water into a building around any intersection or projection in a roof such as vent pipes, chimneys, adjoining walls, dormers and valleys. Galvanized metal flashing should be minimum 26-gauge.

Flashing cement: See Asphalt Roof Cement.

FM Global: A service mark of the Factory Mutual Insurance Company.

Free-Tab Shingles: Shingles that do not contain factory-applied strips or spots of self-sealing adhesive.

Gable: The upper triangular portion of a sidewall that comes to a point at the ridge of a double sloping roof. (See Figure B.)

Gable Roof: A simple two-sided roof above a gable.

Gambrel Roof: A type of roof containing two sloping planes of different pitch on each side of the ridge. The lower plane has a steeper slope than the upper. Contains a gable at each end.

Granules: Typically ceramic-coated colored crushed rock that is applied to the exposed surface of asphalt roofing products.

Gutter: The trough that channels water from the eaves to the downspouts.

Head Lap: Shortest distance from the butt edge of an overlapping shingle to the upper edge of a shingle in the second course below. The triple coverage portion of the top lap of strip shingles. (See Figure A.)

Hexagonal Shingles: Shingles that have the appearance of a hexagon after installation.

Hip: The inclined external angle formed by the intersection of two sloping roof planes. Runs from the ridge to the eaves. (See Figure B.)

Hip Roof: A type of roof containing sloping planes on each of four sides. Contains no gables.



Hip Shingles: Shingles used to cover the inclined external angle formed by the intersection of two sloping roof planes.

Ice Dam: Condition formed at the lower roof edge by the thawing and re-freezing of melted snow on the overhang. Can force ponded water up and under shingles, causing leaks.

Interlocking Shingles: Individual shingles that mechanically fasten to each other to provide wind resistance.

Laminated Shingles: Strip shingles containing more than one layer to create extra thickness. Also called three-dimensional shingles or architectural shingles.

Lap: To cover the surface of one shingle or roll with another.

Lap Cement: An asphalt-based cement (conforming to ASTM D3019) used to adhere overlapping plies of roll roofing.

Low Slope Application: Method of installing asphalt shingles on roof slopes 2"- 4" per foot.

Mansard Roof: A type of roof containing two sloping planes of different pitch on each of four sides. The lower plane has a much steeper pitch than the upper, often approaching vertical. (See Figure B.)

Masonry Primer: An asphalt-based primer used to prepare masonry surfaces for bonding with other asphalt products.

Mastic: See Asphalt Roof Cement.

Mid-ply Sheet: see Base-ply sheet.

Mineral Stabilizers: Finely ground limestone, slate, trap rock or other inert materials added to asphalt coatings for durability and increased resistance to fire and weathering.

Mineral-Surfaced Roofing: Asphalt shingles and roll roofing that are covered with granules.

Nesting: A method of reroofing with new asphalt shingles over old shingles in which the top edge of the new shingle is butted against the bottom edge of the existing shingle tab.

No-Cutout Shingles: Shingles consisting of a single, solid tab with no cutouts.

Non-Veneer Panel: Any wood-based panel that does not contain a laminated veneer and carries an APA span rating, such as wafer board or oriented strand board.

Open Valley: Method of valley construction in which shingles on both sides of the valley are trimmed along a chalk line snapped on each side of the valley. Shingles do not extend across the valley. Valley flashing is exposed.

Organic Felt: An asphalt roofing base material manufactured from cellulose fibers.

Overhang: That portion of the roof structure that extends beyond the exterior walls of a building.

Pallets: Wooden platforms used for storing and shipping bundles of shingles.

Pitch: The degree of roof incline expressed as the ratio of the rise, in feet, to the span, in feet; pitch is 1/2 of slope.

Ply: A layer of roofing (i.e., one-ply, two-ply).

Ponding: The accumulation of water after rainfall at low-lying areas on a roof that remains wet when other parts of the roof have dried.

Racking: Roofing application method in which shingle courses are applied vertically up the roof.

Rafter: The supporting framing member immediately beneath the deck, sloping from the ridge to the wall plate.

Rake: The inclined edge of a sloped roof over a wall. (See Figure B.)

Random-Tab Shingles: Shingles on which tabs vary in size and exposure.

Release Tape: A plastic or paper strip that is applied to the back of self-sealing shingles. This strip prevents the shingles from sticking together in the bundles, and need not be removed for application.

Reroofing: The process of recovering or replacing an existing roofing system.

Ridge: The uppermost, horizontal external angle formed by the intersection of two sloping roof planes. (See Figure B.)

Ridge Shingles: Shingles used to cover the horizontal external angle formed by the intersection of two sloping roof planes.

Rise: The vertical distance from the eaves line to the ridge.

Roll Roofing: Asphalt roofing products manufactured in roll form.

Roofing Tape: An asphalt-saturated tape used with asphalt cements for flashing and patching asphalt roofing.

Run: The horizontal distance from the eaves to a point directly under the ridge. One half the span.

Saturant: Asphalt used to impregnate an organic felt base material.

Saturated Felt: An asphalt-impregnated felt used as an underlayment between the deck and the roofing material.

Self-Adhering Shingle Underlayment: A self-adhering waterproofing shingle underlayment designed to protect against water infiltration due to ice dams or wind driven rain.

Self-Sealing Shingles: Shingles containing factory-applied strips or spots of self-sealing adhesive.

Self-Sealing Strip or Spot: Factory-applied adhesive that bonds shingle courses together when exposed to the heat of the sun after application.

Selvage: That portion of roll roofing overlapped by the succeeding course to obtain single or double coverage at the lap.

Shading: Slight differences in shingle color that may occur as a result of normal manufacturing operations.

Sheathing: See Deck.



Shed Roof: A roof containing only one sloping plane. Has no hips, ridges, valleys or gables.

Single Coverage: Asphalt roofing that provides one layer of roofing material over the deck.

Slope: The roof incline expressed as the ratio of the rise, in inches, to twelve inches of run.

Smooth-Surfaced Roofing: Roll roofing that is covered with fine mineral matter instead of granules (coated).

Soffit: The finished underside of the eaves.

Soil Stack: A vent pipe that penetrates the roof.

Span: The horizontal distance from eave to eave.

Square: A unit of roof measure covering 100 square feet.

Square-Tab Shingles: Shingles on which tabs are all the same size and exposure.

Standard Slope Application: Method of installing asphalt shingles on roof slopes 4" - 21" per foot.

Starter Strip: Asphalt roofing applied at the eave that provides protection by filling in the spaces under the cutouts and joints of the first course of shingles.

Steep Slope Application: Method of installing asphalt shingles on roof slopes greater than 21" per foot.

Step Flashing: Base flashing application method used where a vertical surface meets a sloping roof plane.

Strip Shingles: Asphalt shingles that are approximately three times as long as they are wide.

Tab: The exposed portion of strip shingles defined by cutouts. (See Figure A.)

Talc: See Back Surfacing.

Tear Off: To remove an existing roofing system down to the structural deck.

Telegraphing: A shingle distortion that may arise when a new roof is applied over an uneven surface.

Three-Dimensional Shingles: See laminated shingles.

Top Lap: That portion of the roofing covered by the succeeding course after installation. (See Figure A.)

UL: Underwriters Laboratories, LLC

UL Label: Label displayed on packaging to indicate the level of fire and/or wind resistance of asphalt roofing.

Underlayment: Asphalt saturated felt or other material typically delivered in a roll, used beneath roofing to provide additional protection for the deck.

Valley: The internal angle formed by the intersection of two sloping roof planes. (See Figure B.)



Vapor Retarder: Any material used to prevent the passage of water vapor.

Vent: Any outlet for air that protrudes through the roof deck such as a pipe or stack. Any device installed on the roof, gable or soffit for the purpose of ventilating the underside of the roof deck.

Vent Sleeve: See Collar.

Woven Valley: Method of valley construction in which shingles from both sides of the valley extend across the valley and are woven together by overlapping alternate courses as they are applied. The valley flashing is not exposed.



METRIC CONVERSION TABLES

Measurements in this manual are indicated using the inch-pound (English) system of measurement. Many material standards and building codes indicate measurements in both inch-pound units and in units of the International System of Units (SI) or metric system. SI (metric) units are often required by Federal agencies for construction drawings and specifications. In many construction industry standards, SI units take precedence over inch-pound units. These tables are provided to enhance the usefulness of this manual and as tools to convert from inch-pound units to SI units, and from SI units to inch-pound units when the customer's requirements stipulate use of SI units.

1 foot (ft) or (') = 12 inches (in) or (")

1 meter = 100 cm = 1000 mm

1 yard = 3 feet = 36 inches

1 pound (lb) = 16 ounces (oz)

1 square foot = 144 square inches

1 ton (short) = 2000 lb

1 square of roofing = 100 square feet

1 kilogram = 1000 grams (g)

1 centimeter (cm) = 10 millimeters (mm)

IP (English) to SI (Metric) Units

	To convert from	To	Multiply by
Linear Measure	inches (in) or (")	millimeters (mm)	25.4
	feet (ft) or (')	millimeters (mm)	304.8
	feet (ft) or (')	meters (m)	0.3048
	yard	millimeters (mm)	914.4
	yard	meters (m)	0.9144
Area Measure	square inches (sq in)	square centimeter (sq cm)	6.4513
	square feet (sq ft)	square meters (sq m)	0.0929
	square of roofing (100 sq ft)	square meters (sq m)	9.29
Mass (Weight) Measure	ounces (oz)	gram (g)	28.35
	ounces (oz)	kilogram (kg)	0.02835
	pound (lb)	gram (g)	453.59
	pound (lb)	kilogram (kg)	0.45359

SI (Metric) to IP (English) Units

	To convert from	To	Multiply by
Linear Measure	millimeters (mm)	inches (in) or (")	0.039379
	millimeters (mm)	feet (ft) or (')	0.00328
	meters (m)	feet (ft) or (')	3.2808
	millimeters (mm)	yard	0.00109
	meters (m)	yard	1.0936
Area Measure	square centimeter (sq cm)	square inches (sq in)	0.1550
	square meters (sq m)	square feet (sq ft)	10.7639
	square meters (sq m)	square of roofing (100 sq ft)	0.10764
Mass (Weight) Measure	gram (g)	ounces (oz)	0.0353
	kilogram (kg)	ounces (oz)	35.274
	gram (g)	pound (lb)	0.00220
	kilogram (kg)	pound (lb)	2.2046

Nominal IP and SI Equivalents of Steel Sheet Metal Gauges						
Gauge	Uncoated Steel		Galvanized Steel		Stainless Steel	
	inch	mm	inch	mm	inch	mm
20	0.0359	0.91	0.040	1.01	0.0375	0.95
22	0.0299	0.75	0.034	0.86	0.0312	0.79
24	0.0239	0.60	0.028	0.71	0.0250	0.63
25	0.0209	0.53	0.025	0.63	---	---
26	0.0179	0.45	0.022	0.55	0.0187	0.47
28	0.0149	0.37	0.019	0.48	0.0156	0.39

IP and SI Sheet Aluminum Thicknesses				
inch	0.032	0.040	0.050	0.063
mm	0.813	1.016	1.270	1.600

[Note]

For copper flashing, 16 oz/sq ft is equal to 0.55 mm thickness.

While gauge numbers are commonly used, they are imprecise; therefore specifications and orders should be based on decimal thicknesses.



ARMA TECHNICAL BULLETINS

Technical bulletins are available from ARMA that cover specific topics.

Title

The 2010 Florida Building Code, Residential and Asphalt Shingle Wind Classifications

The 2010 Florida Building Code, Building and Asphalt Shingle Wind Classifications

Algae Discoloration of Roofs

Application of Asphalt Shingles to Decks Installed over Insulation or Radiant Barriers

Cold Weather Recommendations for Applications of Asphalt Roofing Shingles

Color Shading of Asphalt Shingle Roofs

Field Applied Coating of Installed Asphalt Shingles

Hot Weather Recommendations for Storage and Application of Asphalt Roofing Shingles

How to Shingle a Cone Roof

Installation of Self-Adhering Membranes In Steep Slope Roofing

Nail Application of Asphalt Strip Shingles for New and Recover Roofing

Photovoltaic Systems and Asphalt Shingle Roofs

Plain Facts About Buckled Shingles

Preventing Damage from Ice Dams

Re-roofing: Tear Off vs. Re-Cover

Re-roofing with Metric Shingles

Recommendations for Application of Asphalt Shingles on Steep Slopes and Mansard Construction

Sampling Shingles For ASTM Testing

Self-Adhering Underlayment Removal Prior to Steep Slope Re-Roofing

Use of Asphalt Shingle Underlayment

Ventilation and Moisture Control for Residential Roofing

Water Soluble Residue Found on Asphalt Roofing Products

When Does a Shingle Comply with ASTM D3462?

Technical bulletins are developed as needed and additional subject matters may be available. Call ARMA at (202) 591-2450 or go to www.asphaltroofing.org to see which bulletins are currently available.



INDEX

- Algae Discoloration 106
- ARMA Technical Bulletins 116
- Asphalt 7
- Base Material
 - fiberglass 7-8
 - organic 7-8
 - purpose of 1
- Cements
 - asphalt roof cement 25
 - lap cement 25
- Chalk Lines 50
- Cold Curl 28
- Color Shading 29, 104
- Concealed Nail Method 94-95
- Coverage 27
- Cricket 72-73
- Decking
 - materials 18
 - preparation
 - general 19-20
 - when reroofing 85-87
 - radiant barrier 19
- Double Coverage Roll Roofing
 - application
 - hips and ridges 99-100
 - parallel to eaves 98-99
 - parallel to rake 98
 - usage and handling 97-98
 - weights and measures 3
- Drainage 17
- Drip Edge 20-21
- Estimating Area
 - complex roofs 32-38
 - additional material 39
 - pitch and slope 38-39
 - simple roofs 31-32
- Exposed Nail Method 95-97
- Exposure 27
- Factory-Applied Adhesive 28
- Fiberglass Mat 1, 7-8
- Fire Resistance
 - classes 11-12
 - requirements 12
- Flashing
 - apron flashing 74
 - chimneys 72-77
 - corner flashing 75
 - counter flashing 76
 - eave flashing
 - low slopes 82
 - new construction 47-48
 - when reroofing 88
 - soil stacks 71-72
 - step flashing 69-70
 - valleys, application in
 - closed cut valleys 49-50
 - open valleys 48-49
 - woven valleys 49-50
 - vent pipe 71-72
 - vertical wall 70
 - vertical sidewall 69-70
- Fungus Growth. *See Algae Discoloration*
- Gable Roof 17
- Gambrel Roof 17
- Granules, Mineral 1
- Hip Roof 17
- Ice Dams 47
- Inorganic Base Material. *See Base Material: fiberglass*
- Inspection 103-104
- Iron Staining 105
- Laboratories, Testing 13
- Maintenance 105-106
- Mansard Roof 17
- Metric Conversion Tables 114-115
- Nails. *See Roofing Nails*
- Pitch. *See Slope*
- Power Nailers 42-43
- Primer 25



Products, asphalt roofing

- advantages of 6
- components of 1
- fire resistance 11-12, 27
- manufacturing
 - asphalt 7
 - process 8-9
 - quality control 10
- research 11
- roofing fabric 25
- selection of 27
- storage of 10, 26
- types of 1

Radiant Barrier Decks 19

Reroofing

- bridging 89
- deck preparation 85-88
- flashing
 - chimneys 91
 - eave flashing 88
 - soil stacks 91
 - valley flashing 90
- vent pipes 91
 - vertical sidewall (over asphalt shingles) 91
- nesting 89
- over existing roof
 - old asphalt shingles 87-88
 - old roll roofing 88
- removing existing roof 86-87
- shingle application
 - at hips and ridges 91
 - first course 90
 - second and succeeding courses 90
 - starter strip 89
- underlayment 88

Roll Roofing

- application parallel to eaves
 - concealed nail method 94-95
 - exposed nail method 95-97
 - application parallel to rake 98-99
 - double coverage. *See Double Coverage Roll Roofing*
 - specifications of
 - coverage 3, 27
 - exposure 3, 27
 - weights and measures 3
 - types of
 - mineral surfaced 3-5
 - smooth surfaced 3-5
 - usage and handling 93
- Roof Styles 17
- Roofing Machine 8-9
- Roofing Nails
- corrosion resistance 22
 - length of 22
 - power nailers 43
 - quantity and placement of (strip shingles)
 - at hips and ridges 80
 - in high wind regions 24
 - under normal conditions 23-24
 - recommendations 22
 - specifications of 22-23
- Safety 41
- Saturated Felt. *See Underlayment*
- Self-Adhering Roll Roofing 101-102
- Self-Adhering Shingle Underlayment 3, 5
- Shed Roof 17



Shingles

- aesthetics (appearance) 29
- alignment of. *See Chalk Lines*
- application (low slope) 81
- application laminated shingles (new construction)
 - first and succeeding courses 62
 - hips and ridges 79-80
 - in closed cut valley 67
 - in open valley 64
 - in open valley for dormer roof 64-66
 - preparation 61
 - starter strip 61-62
- application strip shingles (new construction)
 - 4" method 54
 - 5" method 54
 - 6" method 53
 - first and succeeding courses 52-53
 - hips and ridges 79-80
 - in closed cut valley 58-59
 - in open valley 55-56
 - in open valley for dormer roof 56-57
 - in woven valley 59
 - preparation 51-52
 - starter strip 52
- application (steep slope) 83
- color shading 104
- factory-applied adhesive 28
- hand sealing 28
- specifications of
 - coverage 27
 - exposure 2, 27
 - weights and measures 2
- storage of 10, 26
- types of
 - laminated 2, 4
 - strip 1-2, 4

Slope

- calculation of 38-39
- requirements for
 - roll roofing 17-18
 - shingles 17-18

Storage

- shingles 10, 26

Tape, Roofing. *See Products, asphalt roofing: roofing fabric*

Three-dimensional shingles. *See Shingles: types of: laminated*

Tools 42-44

Underlayment. *See also Roll Roofing*

application

- low slopes 81-82

- new construction 45-46

- reroofing 88

usage of 5

weights and measures 3

Valleys

flashing in

- closed cut valleys 49-50

- open valleys 48-49

- woven valleys 49-50

shingle application in

- closed cut valleys 58-59, 67

- open valleys 55-56, 64

- open valleys for dormers 56-57, 64-66

- woven valleys 59

Vapor Retardation 45

Ventilation

- heating and cooling costs, effects on 15-16

- practices 16-17

Wind Resistance 12, 28

Wood Saddle. *See Cricket*



NOTES



**Asphalt Roofing
Manufacturers Association**

National Press Building
529 14th St NW, Suite 750
Washington, DC 20045
Phone: (202) 591-2450